



Scan for full manual

VIA GO² Quick Start Guide For Installer

This guide helps you install and use your VIA GO² for the first time.

Go to <https://www.kramerav.com/product/VIA GO²> to download the latest user manual and check if firmware upgrades are available.

Step 1: Check what's in the box

- ✓ VIA GO² Collaboration Device
- ✓ 1 VESA mounting bracket
- ✓ 1 Quick start guide
- ✓ 1 Power supply (12V DC) with adapters for US, UK, and EU
- ✓ 1 VESA screw set

Step 2: Get to know your VIA GO²

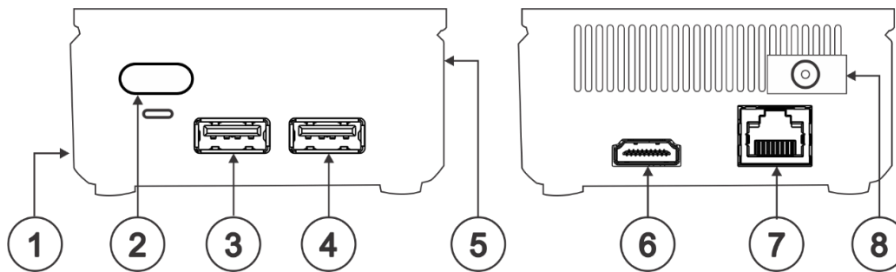

#	Feature	Function
1	Micro SD Card Slot	Not in use.
2	Power Button with LED	Press to power ON or turn OFF the device.
3	USB 3.0 Connector	Connect to a USB device, for example, a keyboard or mouse.
4	USB 2.0 Connector	Connect to a USB device, for example, a keyboard or mouse.
5	Lock Opening	Connect to a security locking cable.
6	HDMI™ Connector	Connect to an HDMI sink.
7	RJ-45 Connector	Connect to a LAN (default mode).
8	Power Connector	Connect to the 12V DC power supply.

Step 3: Mount VIA GO²

Place VIA GO² on a flat surface, or mount on a wall or the back of a display using the included VESA mounting bracket:

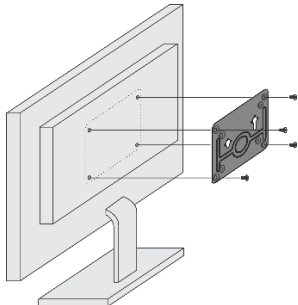

1. Attach the VESA mounting bracket to the back of the display with 4 screws.

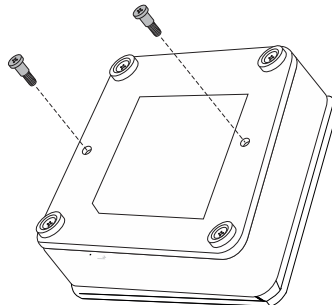

2. Fasten two screws to the bottom of VIA GO².

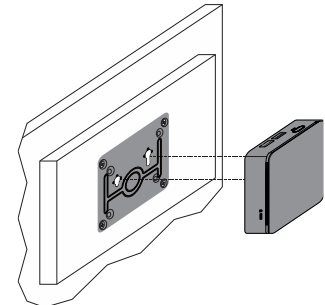

3. Insert the screws on the bottom of VIA GO² into the slots on the mounting bracket.



When mounting the device on a display, the installer MUST secure the display to prevent instability.

Step 4: Connect inputs and outputs

Always switch OFF the power on each device before connecting it to your VIA GO².

1. Connect the keyboard and mouse.
2. Connect an HDMI display.
3. Connect to the LAN (default mode).

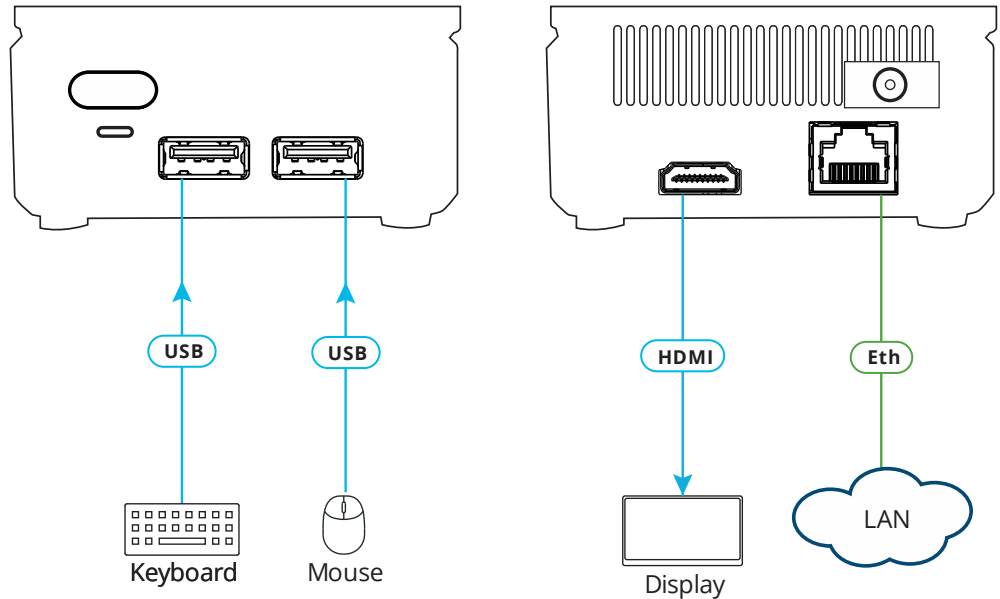

If you wish to use a Kramer active optical pluggable HDMI cable with your VIA GO², contact your local Kramer office to assist in purchasing the correct cable.



To achieve specified extension distances, use the recommended Kramer cables available at [www.kramerav.com/product/VIA GO²](http://www.kramerav.com/product/VIA_GO2).
Using third-party cables may cause damage!

Step 5: Connect power

Connect the 12V DC power adapter to VIA GO² and plug it into the mains electricity.



- Caution:** There are no operator serviceable parts inside the unit.
 - Caution:** The device is intended to be installed at a height of 2 meters or less.
 - Warning:** Use only the Kramer Electronics power adapter that is provided with the unit.
 - Warning:** Disconnect the power and unplug the unit from the wall before installing.
- See www.KramerAV.com for updated safety information.

Step 6: Configure VIA GO²

A wizard guides you through configuration.

For more information about configuration see “**For Web Administrator: Gateway Management pages**” in the User Manual.

If you choose to skip the wizard, follow the basic configuration steps described below. For more information see “**For Web Administrator: Gateway Dashboard**” in the User Manual.

1. Click the VIA tile at the bottom left of the screen: The Gateway Dashboard will open.
2. On the **Kramer Gateway Dashboard**, click **Settings**: The settings login window appears.
3. Enter the User Name (default = su) and Password (default = supass) and click **Login**: The VIA Settings window appears.

The VIA Settings tabs are:

- LAN Settings – Configure network parameters (default = DHCP allocated IP).
- System Controls – Manage your display and audio settings.
- Wifi – Activate and configure the built-in Wi-Fi capability.

4. When you have finished configuring settings, click **Reboot** to apply all settings.

The screenshot shows the VIA Settings login window. It has a dark background with white text. At the top left, there is a 'VIA' logo. Below it, there are two input fields: 'User Name:' with the text 'su' and 'Password:'. At the bottom right, there are two buttons: 'Login' and 'Cancel'.

To enable Wi-Fi:

1. Click the Wi-Fi tab and switch on **Wi-Fi**. The switch turns green and additional Wi-Fi settings appear.
2. Choose between **AP Mode** and **Client Mode**: AP Mode sets the VIA Go² as an independent Wi-Fi network, Client Mode connects the VIA Go² to an existing Wi-Fi network, making it a secondary access point for guests.
 - Defining **AP Mode**: Enter a new name in the SSID field and a new password or use the default name and password. Select a Wi-Fi channel for the Access Point. Select **Enable Internet** if the primary LAN network is connected to the Internet OR **Activate Standalone Wi-Fi** to create an autonomous network without Internet access, and click **Apply**.
 - Defining **Client Mode**: Select an available network from the drop-down, enter the password and click **Apply**. Disconnect the LAN cable (if connected).
3. Reboot the device.



Scan for full manual

VIA GO² Quick Start Guide

For User

This guide helps you install and use your VIA GO² for the first time.

Go to <https://www.kramerav.com/product/VIA GO²> to download the latest user manual.

Step 1: Connect your personal device to the proper network

Connect your personal device to the same Wi-Fi or LAN network as the VIA GO² in your meeting room.

Step 2: Run or Download the Kramer VIA app

See "Installing or Running the VIA app" in the User Manual.

For Mac or PC:

1. Enter the Room Name or IP of the VIA GO² in your computer's browser. The Welcome page of VIA GO² appears.

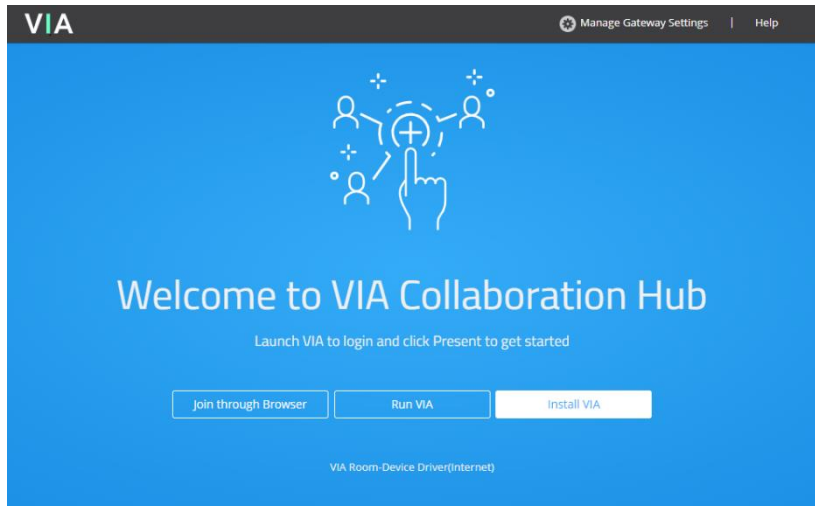

2. Click **Run VIA** to execute the **Kramer VIA** app without downloading it. For guests who are using VIA temporarily. OR Click **Install VIA** to download the **Kramer VIA** app onto your computer. For regular users of the VIA.

For iOS or Android devices: Download and install the free **Kramer VIA** app from Apple App Store or Google Play.

Step 3: Join the meeting using Kramer VIA App

See "Joining a Room with the VIA app" in the User Manual.

1. Open the Kramer VIA app and select the room or IP to which you want to connect: If your site requires a Room Code, the Room Code window will appear.
2. In the Room Code field, enter the 4-digit code as it appears on the Main Display.
3. You are logged into the VIA meeting.
The VIA Dashboard appears on your device screen (see next page).

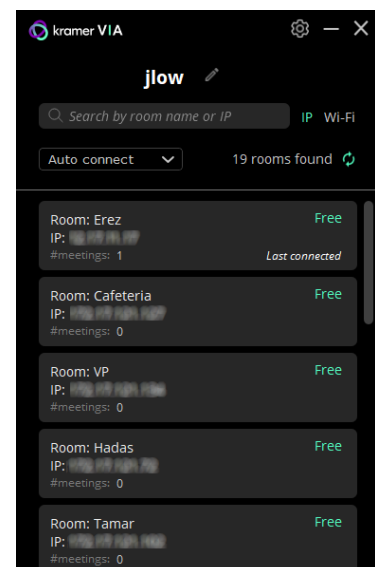

Step 4: Using the VIA dashboard menu

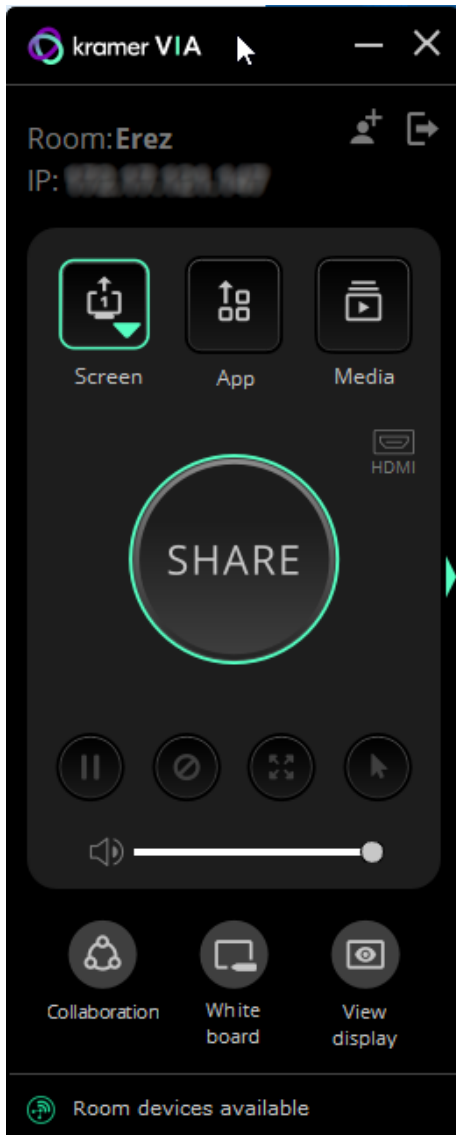

For more information see “Presenting from the VIA User Dashboard” in the User Manual.

1. Select what you want to share:
 - **Screen** – Share your screen.
 - **App** – Share a window or a third party app.
 - **Media** – Share (stream) a media file.

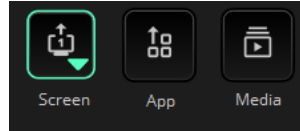

2. Click SHARE:
 - The SHARE button becomes the STOP button.
 - Your screen, app or media will be displayed to meeting participants (on the main display).
3. Click the green arrow on the right to view participants, chat or to send files.

Bottom of VIA dashboard

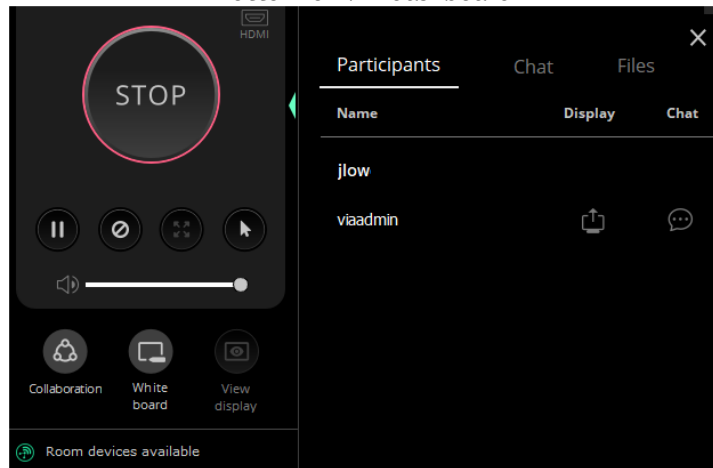

4. Use the 4 buttons below STOP to control sharing.
5. Use the 3 buttons at the bottom for collaborating with other participants.
6. Click STOP to end sharing.

Step 5: VIA GO² Features



Wireless Connection



Powerful Content Security



Video Streaming



Mobile Mirroring



VIA Site Management (VSM)



Digital Signage



Calendar Integration



VIA Pad Compatible



Integrated YouTube Player

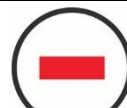

Do Not Disturb (DND)

Specifications are subject to change without notice at www.kramerav.com

The terms HDMI, HDMI High-Definition Multimedia Interface, and the HDMI Logo are trademarks or registered trademarks of HDMI Licensing Administrator, Inc.