



# USERS GUIDE INFOCUS LIGHTPRO VISTA II, GENESIS III, GENESIS IV SERIES

**InFocus**

REGULATORY MODE	SERIES NAME	LENS TYPE/RESOLUTION	SVGA	XGA	WXGA	1080P
P122	INFOCUS LIGHTPRO VISTA II	STANDARD THROW	–	IN0044SL	IN0046SL	IN0048SL
P123	INFOCUS LIGHTPRO VISTA II	SHORT THROW	–	IN0044ST	IN0046ST	IN0048ST
P124	INFOCUS LIGHTPRO GENESIS III	STANDARD THROW	IN0002SL	IN0004SL	IN0006SL	-
P125	INFOCUS LIGHTPRO GENESIS IV	STANDARD THROW	IN0022SL	IN0024SL	IN0026SL	IN0028SL
P126	INFOCUS LIGHTPRO GENESIS IV	SHORT THROW	–	IN0024ST	IN0026ST	-



## TABLE OF CONTENTS

<b>1. ABOUT THIS GUIDE.....</b>	<b>5</b>
1.1 DESCRIPTION OF THE USER .....	5
1.2 CONVENTIONS USED IN THIS GUIDE.....	5
1.3 EXPLANATION OF SAFETY WARNINGS .....	5
1.4 RETAINING INSTRUCTIONS .....	5
1.5 OBTAINING DOCUMENTATION AND INFORMATION .....	6
1.6 DOCUMENTATION FEEDBACK.....	6
1.7 SUPPORT AND SERVICE.....	6
<b>2. PRODUCT DESCRIPTION.....</b>	<b>7</b>
2.1 FEATURES .....	7
2.2 INTENDED USE AND REASONABLY FORESEEABLE MISUSE .....	9
2.3 PRODUCT ELEMENTS.....	9
2.3.1 FRONT.....	9
2.3.2 RIGHT SIDE .....	10
2.3.3 LEFT SIDE .....	11
2.3.4 TOP.....	12
2.3.5 BACK.....	13
<b>3. SAFETY .....</b>	<b>15</b>
3.1 HOW TO USE THE PRODUCT SAFELY.....	15
3.1.1 VULNERABLE PEOPLE SAFETY INFORMATION.....	15
3.1.2 TECHNICAL LIFE SPAN.....	15
3.1.3 INTENDED USE SAFETY INFORMATION.....	15
3.1.4 INSTALLATION SAFETY INFORMATION.....	15
3.1.5 ELECTRICAL SAFETY INFORMATION.....	15
3.1.6 SAFETY INFORMATION .....	15
3.1.7 MAINTENANCE SAFETY INFORMATION .....	16
3.1.8 SERVICE AND REPAIR SAFETY INFORMATION .....	16
3.2 SAFE DISPOSAL .....	16
3.3 GRAPHICAL SYMBOLS .....	16
<b>4. UNPACKING AND INSTALLING .....</b>	<b>17</b>
4.1 PACKAGING CONTENTS .....	17
4.2 INSTALLATION INSTRUCTIONS .....	17
4.3 PLACEMENT AND DISTANCE FROM THE SCREEN .....	17
4.3.1 PROJECTION DISTANCE AND SCREEN SIZE.....	17
4.4 CLEARANCE.....	24
4.5 CEILING MOUNT .....	25
4.6 MOUNTING HOLE DIAGRAM .....	26
<b>5. ADJUSTING .....</b>	<b>27</b>
5.1 ADJUSTING THE IMAGE HEIGHT AND TILT .....	27
5.2 ADJUSTING THE ZOOM, LENS SHIFT AND FOCUS.....	27
5.3 ADJUSTING THE VERTICAL AND HORIZONTAL KEYSTONE .....	27
<b>6. CONNECTING .....</b>	<b>29</b>
6.1 CONNECTION DIAGRAM .....	29
<b>7. USING .....</b>	<b>30</b>
7.1 LEDS .....	30

7.2	KEYPAD.....	30
7.3	KEYPAD.....	31
7.3.1	INSTALLING BATTERIES IN THE REMOTE CONTROL.....	32
7.3.2	REMOTE CONTROL IR CODES.....	33
7.4	REMOTE CONTROL EFFECTIVE RANGE.....	33
7.5	TURNING THE PROJECTOR ON.....	34
7.6	SELECTING A INPUT SOURCE.....	34
7.7	TURNING THE PROJECTOR TO STANDBY MODE.....	34
7.8	VIEWING 3D CONTENT.....	35
7.8.1	PHOTOSENSITIVE SEIZURE WARNING AND OTHER HEALTH RISKS.....	35
7.8.2	ENABELING 3D MODE.....	36
7.8.3	ENABLING AUTO 3D MODE.....	36
<b>8.</b>	<b>USING THE ON SCREEN DISPLAY (OSD).....</b>	<b>37</b>
8.1	SELECTING THE LANGUAGE FOR THE ON SCREEN MENU.....	37
8.2	SELECTING A DISPLAY MODE.....	37
8.3	ADJUSTING THE IMAGE COLOUR AND TEMPERATURE.....	38
8.4	ADJUSTING THE SHARPNESS OF THE IMAGE.....	38
8.5	MAGNIFYING THE IMAGE.....	38
8.6	SELECTING AN ASPECT RATIO.....	38
8.7	ADJUSTING THE BRIGHTNESS.....	38
8.8	ENABELING ECO MODE.....	39
8.9	ENABLING CLOSED CAPTIONS.....	39
8.10	DISPLAYING A TEST PATTERN.....	39
8.11	PREVENTING UNAUTHORIZED USE.....	39
8.12	CHANGING THE PASSWORD.....	39
8.13	CONTROLLING THE PROJECTOR FROM A WEB BROWSER.....	40
8.14	DIRECTLY CONNECTING A COMPUTER TO THE PROJECTOR.....	45
<b>9.</b>	<b>CLEANING.....</b>	<b>45</b>
9.1	CLEANING THE LENS.....	45
9.2	CLEANING THE CASE.....	45
9.3	CLEANING THE AIR VENTS.....	45
<b>10.</b>	<b>SANITATION.....</b>	<b>45</b>
<b>11.</b>	<b>DISPOSAL.....</b>	<b>46</b>
11.1	DISPOSAL OF ELECTRICAL COMPONENTS.....	46
11.2	DISPOSAL OF PACKAGING WASTE.....	46
<b>12.</b>	<b>TROUBLESHOOTING.....</b>	<b>47</b>
12.1	LED INDICATOR LIGHTS.....	47
12.2	SOLVING ON / OFF ISSUES.....	47
12.3	SOLVING IMAGE ISSUES.....	47
12.4	SOLVING VIDEO, AUDIO AND REMOTE CONTROL ISSUES.....	48
12.5	SERVICING.....	48
<b>13.</b>	<b>ADDITIONAL INFORMATION.....</b>	<b>49</b>
13.1	RS232 PIN ASSIGNMENTS.....	49
13.2	RS232 PROTOCOL FUNCTION LIST.....	49
13.3	SUPPORTED RESOLUTIONS AND REFRESH RATES.....	49
13.4	ON SCREEN DISPLAY (OSD) MENU TREE.....	51
<b>14.</b>	<b>SPECIFICATIONS.....</b>	<b>59</b>
14.1	VISTA II, P122 & P123, SPECIFICATIONS.....	59
14.2	GENESIS III, P124, SPECIFICATIONS.....	61
14.3	GENESIS IV P125 & P126, SPECIFICATIONS.....	63

<b>15. PRODUCT COMPLIANCE.....</b>	<b>65</b>
15.1 FOR USERS IN THE UNITED STATES .....	65
15.2 FOR USERS IN CANADA.....	65
15.3 FOR USERS IN EUROPEAN UNION .....	66
15.4 FOR USERS IN THE UNITED KINGDOM AND NORTHERN IRELAND .....	66
15.5 FOR USERS IN RUISSIA .....	67

## 1.1 DESCRIPTION OF THE USER

This document is intended for anyone who will install, setup, or use the projector.

## 1.2 CONVENTIONS USED IN THIS GUIDE

The following style conventions are used in this document:

### **Bold**

- Names of product elements, commands, options, and programs.
- Names of interface elements (such windows, dialog boxes, buttons, fields, and menus).
- Interface elements the user selects, clicks, taps, or types.

### *Italic*

- Publication titles.
- Emphasis (for example, a new term).

## 1.3 EXPLANATION OF SAFETY WARNINGS



### **WARNING**

“WARNING” indicates a hazard with a medium to high level of risk which, could result in death or serious injury.



### **ATTENTION**

“ATTENTION” indicates a hazard with a low level of risk which, if not avoided, could result in minor or moderate injury.



### **INFORMATION**

“INFORMATION” Indicates information considered important, but not hazardrelated.

## 1.4 RETAINING INSTRUCTIONS

Keep all safety information and instructions for future reference and pass them on to subsequent users of the product.



### **WARNING**

Ensure that each person who uses the product has read and understood this guide and its safety instructions before using this product. Failure to do so can result in serious injury or death.



### **ATTENTION**

Follow all the instructions. This will avoid fire, explosions, electric shocks, or other hazards that may result in damage to property and/or severe or fatal injuries.



### **INFORMATION**

The manufacturer is not liable for cases of material damage or personal injury caused by incorrect handling or non-compliance with the safety instructions. In such cases, the warranty will be voided.

## 1.5 OBTAINING DOCUMENTATION AND INFORMATION

The latest version of this document can be obtained by visiting:

- <https://infocus.com/product/vistaII>
- <https://infocus.com/product/genesisIII>
- <https://infocus.com/product/genesisIV>

## 1.6 DOCUMENTATION FEEDBACK

If you are reading product documentation on the internet, any comments can be submitted Here. We appreciate your comments.

## 1.7 SUPPORT AND SERVICE

Please contact the support team in your region for technical and product support. Alternatively, you may contact your local distributor if you are in Asia or Australia.

### Americas

Monday – Friday

6am – 5pm PST



+1877-388-8360



[support@infocus.com](mailto:support@infocus.com)



[infocus.com/support](https://infocus.com/support)

### Europe, Middle East & Africa

Monday – Friday

8am – 5pm CET



[eusupport@infocus.com](mailto:eusupport@infocus.com)



[infocus.com/support](https://infocus.com/support)

### Asia Pacific

Monday – Friday

8am – 5pm ICT



[apsupport@infocus.com](mailto:apsupport@infocus.com)



[infocus.com/support](https://infocus.com/support)

## 2. PRODUCT DESCRIPTION

### 2.1 FEATURES

	GENESIS III			GENESIS IV				VISTA II							
	P124			P125			P126	P122			P123				
	IN0002SL	IN0004SL	IN0006SL	IN0022SP	IN0024SL	IN0026SL	IN0028SL	IN0024ST	IN0026ST	IN0044SL	IN0046SL	IN0048SL	IN0044ST	IN0046ST	IN0048ST
Nine Picture Modes including DICOM Simulation, User Definable and ISF Night & Day	●	●	●	●	●	●	●	●	●	●	●	●	●	●	●
Seven Wall Colour Modes	●	●	●	●	●	●	●	●	●	●	●	●	●	●	●
Brightness, Sharpness, Contrast, Colour, Tint, Gamma Adjustment Settings	●	●	●	●	●	●	●	●	●	●	●	●	●	●	●
10 Step BrilliantColor Implementation	●	●	●	●	●	●	●	●	●	●	●	●	●	●	●
Individual Hue, Saturation and Gain Adjustments for RGB, C, M, Y, W	●	●	●	●	●	●	●	●	●	●	●	●	●	●	●
RGB Gain/Bias Adjustments	●	●	●	●	●	●	●	●	●	●	●	●	●	●	●
Five Colour Space Adjustment Settings	●	●	●	●	●	●	●	●	●	●	●	●	●	●	●
White and Black Level Adjustments	●	●	●	●	●	●	●	●	●	●	●	●	●	●	●
IRE and Signal Settings and Adjustments	●	●	●	●	●	●	●	●	●	●	●	●	●	●	●
Aspect Ratio Format Settings	●	●	●	●	●	●	●	●	●	●	●	●	●	●	●
4:3	●	●	●	●	●	●	●	●	●	●	●	●	●	●	●
16:9	●	●	●	●	●	●	●	●	●	●	●	●	●	●	●
16:10	●	●	●	●	●	●	●	●	●	●	●	●	●	●	●
Letter Box	●	●	●	●	●	●	●	●	●	●	●	●	●	●	●
Native	●	●	●	●	●	●	●	●	●	●	●	●	●	●	●
Auto	●	●	●	●	●	●	●	●	●	●	●	●	●	●	●
Digital Edge Masking	●	●	●	●	●	●	●	●	●	●	●	●	●	●	●
Digital Image Shift - Horizontal & Vertical	●	●	●	●	●	●	●	●	●	●	●	●	●	●	●
Digital Zoom	●	●	●	●	●	●	●	●	●	●	●	●	●	●	●
Vertical Keystone Adjustment	●	●	●	●	●	●	●	●	●	●	●	●	●	●	●
3D Activation, DLP - Link Settings & Formats	●	●	●	●	●	●	●	●	●	●	●	●	●	●	●
3D Sync Invert	●	●	●	●	●	●	●	●	●	●	●	●	●	●	●
2D to 3D Setting	●	●	●	●	●	●	●	●	●	●	●	●	●	●	●
Enhanced Low Latency Gaming Mode	●	●	●	●	●	●	●	●	●	●	●	●	●	●	●
Picture Mode Lock	●	●	●	●	●	●	●	●	●	●	●	●	●	●	●
27 Selectable OSD Languages	●	●	●	●	●	●	●	●	●	●	●	●	●	●	●
Projection Modes - Front, Rear, Front Ceiling, Rear Ceiling OSD Menu Positioning	●	●	●	●	●	●	●	●	●	●	●	●	●	●	●
Screen Type - Aspect Ratio Locking 16:10	●	●	●	●	●	●	●	●	●	●	●	●	●	●	●
Screen Type - Aspect Ratio Locking 16:9	●	●	●	●	●	●	●	●	●	●	●	●	●	●	●
Security On/Off Setting	●	●	●	●	●	●	●	●	●	●	●	●	●	●	●
Security Timer	●	●	●	●	●	●	●	●	●	●	●	●	●	●	●
Security Password Selector	●	●	●	●	●	●	●	●	●	●	●	●	●	●	●
Assignable Project ID Number	●	●	●	●	●	●	●	●	●	●	●	●	●	●	●
Audio Input and Volume Settings	●	●	●	●	●	●	●	●	●	●	●	●	●	●	●

	GENESIS III			GENESIS IV						VISTA II					
	P124			P125			P126			P122			P123		
	IN0002SL	IN0004SL	IN0006SL	IN0022SP	IN0024SL	IN0026SL	IN0028SL	IN0024ST	IN0026ST	IN0044SL	IN0046SL	IN0048SL	IN0044ST	IN0046ST	IN0048ST
HDMI Link Activation and Settings	●	●	●	●	●	●	●	●	●	●	●	●	●	●	●
Startup Logo Removal and Background Colour	●	●	●	●	●	●	●	●	●	●	●	●	●	●	●
Selector Projector Information Messaging Override	●	●	●	●	●	●	●	●	●	●	●	●	●	●	●
Input Source Lock Auto Source Setting High Altitude Setting Keypad Lock Setting Built in Test Patterns IR Fraction Setting	●	●	●	●	●	●	●	●	●	●	●	●	●	●	●
15 user presets with single key activation Direct Power On Setting	●	●	●	●	●	●	●	●	●	●	●	●	●	●	●
Signal Power On Setting	●	●	●	●	●	●	●	●	●	●	●	●	●	●	●
Auto Power Off Setting	●	●	●	●	●	●	●	●	●	●	●	●	●	●	●
Sleep Timer Setting	●	●	●	●	●	●	●	●	●	●	●	●	●	●	●
Quick Resume Setting	●	●	●	●	●	●	●	●	●	●	●	●	●	●	●
VGA Out Standby Setting	●	●	●	●	●	●	●	●	●	●	●	●	●	●	●
USB-A Power Setting	●	●	●	●	●	●	●	●	●	●	●	●	●	●	●
Lamp Usage Reminder Setting	●	●	●	●	●	●	●	●	●	●	●	●	●	●	●
Lamp Brightness Mode	●	●	●	●	●	●	●	●	●	●	●	●	●	●	●
Projector Information Table	●	●	●	●	●	●	●	●	●	●	●	●	●	●	●
24/7 Operation	●	●	●	●	●	●	●	●	●	●	●	●	●	●	●
Waveform Lamp Colour Enhancement AV Mute	●	●	●	●	●	●	●	●	●	●	●	●	●	●	●
AV Mute	●	●	●	●	●	●	●	●	●	●	●	●	●	●	●
Crestron Connect Certified	●	●	●	●	●	●	●	●	●	●	●	●	●	●	●



## 2.2 INTENDED USE AND REASONABLY FORESEEABLE MISUSE

The product may only be used in accordance with the instructions described in this guide. Any use other than those described in this guide is considered non-intended use and will void the warranty.

The ambient operating environment should be free of airborne smoke, grease, oil, and other contaminants that can affect the operation or performance of the projector.



**WARNING**

**Do not use the product near water or moisture. Do not expose the product to rain, steam or condensation to reduce the risk of fire or electric shock.**

## 2.3 PRODUCT ELEMENTS

### 2.3.1 FRONT

a)



REGULATORY MODEL	SERIES NAME	LENS TYPE/ RESOLUTION	SVGA	XGA	WXGA	1080P
P122	INFOCUS LIGHTPRO VISTA II	STANDARD THROW	-	IN0044SL	IN0046SL	IN0048SL
P124	INFOCUS LIGHTPRO GENESIS III	STANDARD THROW	IN0002SL	IN0004SL	IN0006SL	-
P125	INFOCUS LIGHTPRO GENESIS IV	STANDARD THROW	IN0022SL	IN0024SL	IN0026SL	IN0028SL

b)



REGULATORY MODEL	SERIES NAME	LENS TYPE/ RESOLUTION	SVGA	XGA	WXGA	1080P
<b>P123</b>	INFOCUS LIGHTPRO VISTA II	SHORT THROW	-	IN0044ST	IN0046ST	IN0048ST
<b>P126</b>	INFOCUS LIGHTPRO GENESIS IV	SHORT THROW	-	IN0024ST	IN0026ST	-

## 2.3.2 RIGHT SIDE

a)

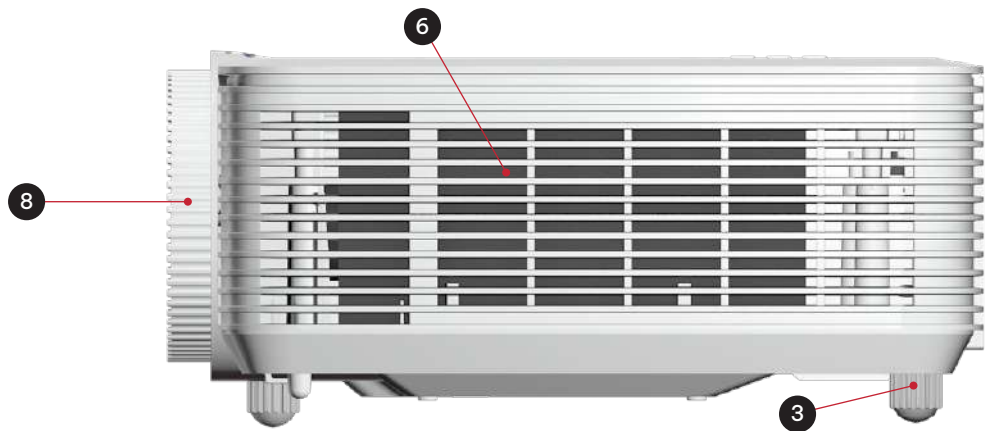

REGULATORY MODEL	SERIES NAME	LENS TYPE/ RESOLUTION	SVGA	XGA	WXGA	1080P
<b>P122</b>	INFOCUS LIGHTPRO VISTA II	STANDARD THROW	-	IN0044SL	IN0046SL	IN0048SL
<b>P124</b>	INFOCUS LIGHTPRO GENESIS III	STANDARD THROW	IN0002SL	IN0004SL	IN0006SL	-
<b>P125</b>	INFOCUS LIGHTPRO GENESIS IV	STANDARD THROW	IN0022SL	IN0024SL	IN0026SL	IN0028SL

b)

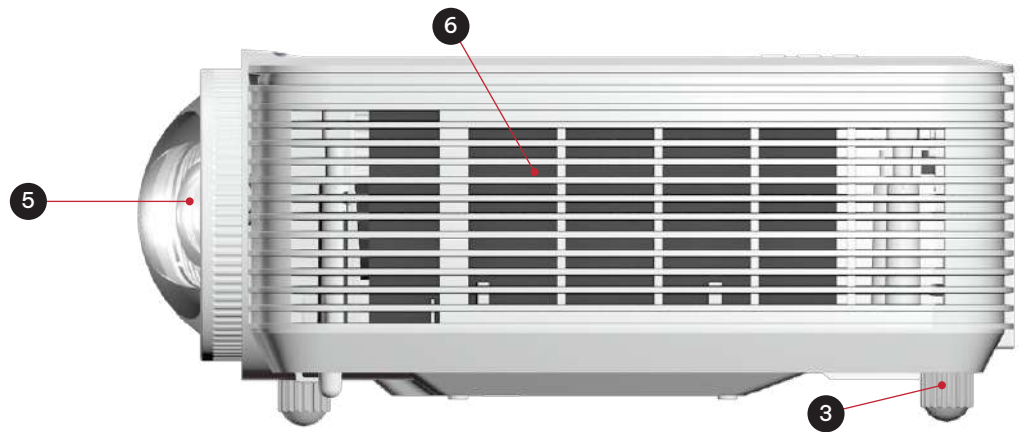

REGULATORY MODEL	SERIES NAME	LENS TYPE/ RESOLUTION	SVGA	XGA	WXGA	1080P
<b>P123</b>	INFOCUS LIGHTPRO VISTA II	SHORT THROW	-	IN0044ST	IN0046ST	IN0048ST
<b>P126</b>	INFOCUS LIGHTPRO GENESIS IV	SHORT THROW	-	IN0024ST	IN0026ST	-

### 2.3.3 LEFT SIDE

a)

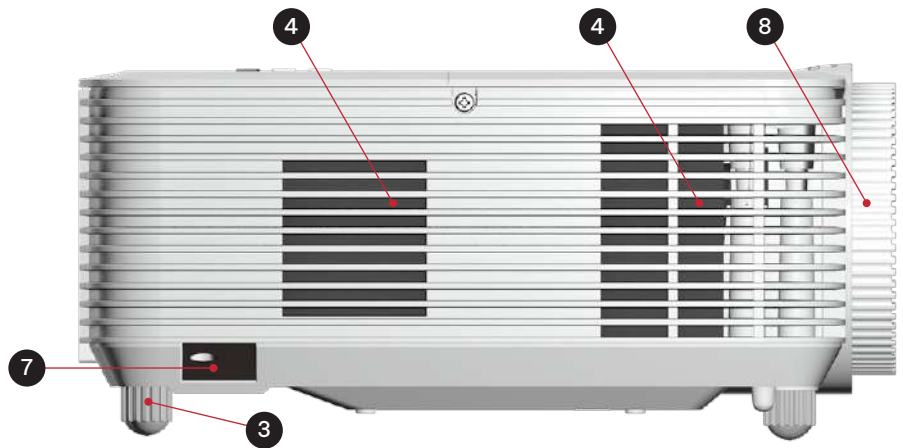

REGULATORY MODEL	SERIES NAME	LENS TYPE/ RESOLUTION	SVGA	XGA	WXGA	1080P
<b>P122</b>	INFOCUS LIGHTPRO VISTA II	STANDARD THROW	-	IN0044SL	IN0046SL	IN0048SL
<b>P124</b>	INFOCUS LIGHTPRO GENESIS III	STANDARD THROW	IN0002SL	IN0004SL	IN0006SL	-
<b>P125</b>	INFOCUS LIGHTPRO GENESIS IV	STANDARD THROW	IN0022SL	IN0024SL	IN0026SL	IN0028SL

b)

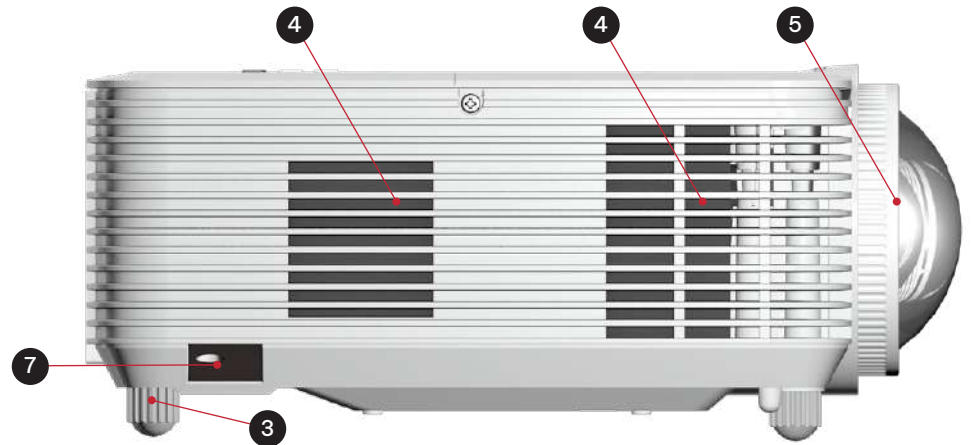

REGULATORY MODEL	SERIES NAME	LENS TYPE/ RESOLUTION	SVGA	XGA	WXGA	1080P
P123	INFOCUS LIGHTPRO VISTA II	SHORT THROW	-	IN0044ST	IN0046ST	IN0048ST
P126	INFOCUS LIGHTPRO GENESIS IV	SHORT THROW	-	IN0024ST	IN0026ST	-

## 2.3.4 TOP

a)

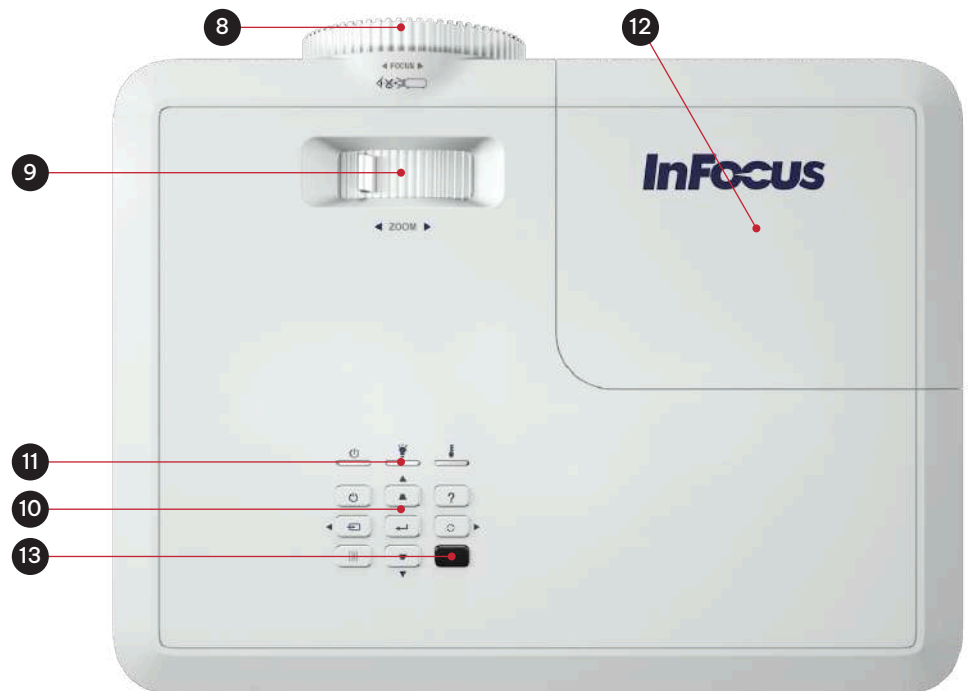

REGULATORY MODEL	SERIES NAME	LENS TYPE/ RESOLUTION	SVGA	XGA	WXGA	1080P
P122	INFOCUS LIGHTPRO VISTA II	STANDARD THROW	-	IN0044SL	IN0046SL	IN0048SL
P124	INFOCUS LIGHTPRO GENESIS III	STANDARD THROW	IN0002SL	IN0004SL	IN0006SL	-
P125	INFOCUS LIGHTPRO GENESIS IV	STANDARD THROW	IN0022SL	IN0024SL	IN0026SL	IN0028SL

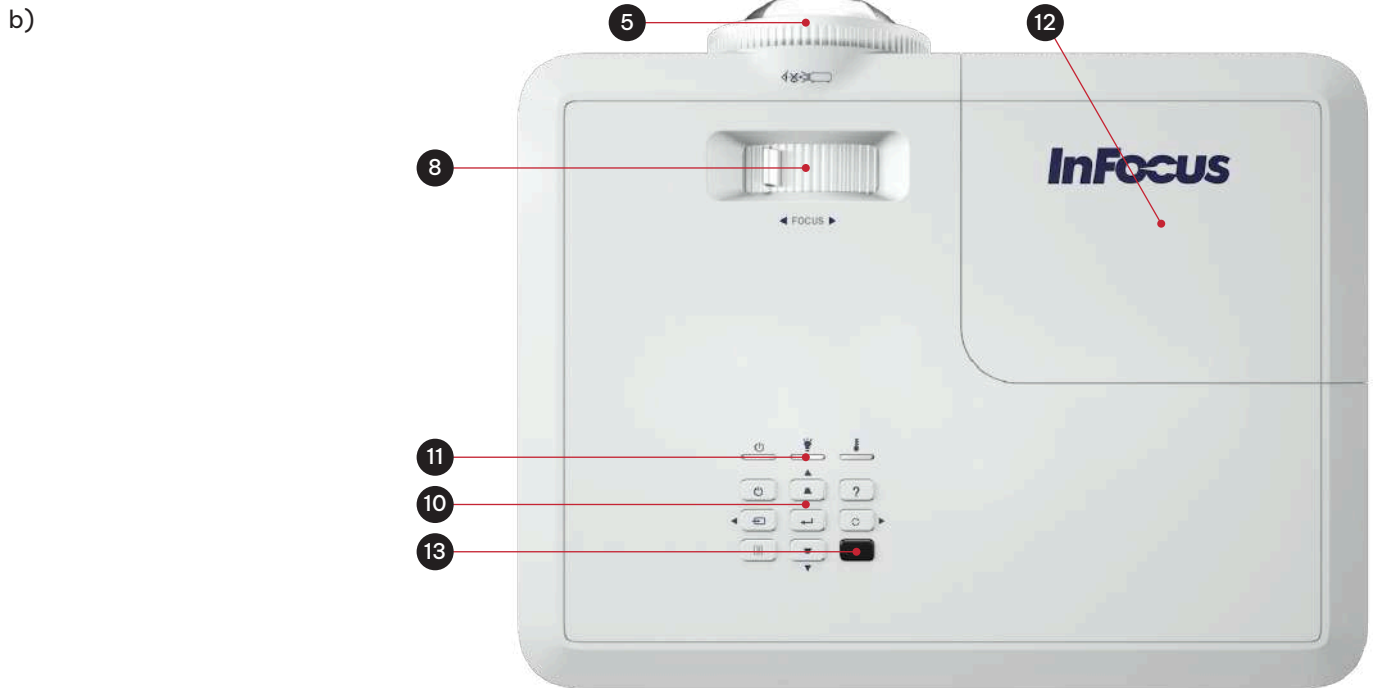

REGULATORY MODEL	SERIES NAME	LENS TYPE/ RESOLUTION	SVGA	XGA	WXGA	1080P
P123	INFOCUS LIGHTPRO VISTA II	SHORT THROW	-	IN0044ST	IN0046ST	IN0048ST
P126	INFOCUS LIGHTPRO GENESIS IV	SHORT THROW	-	IN0024ST	IN0026ST	-

### 2.3.5 BACK

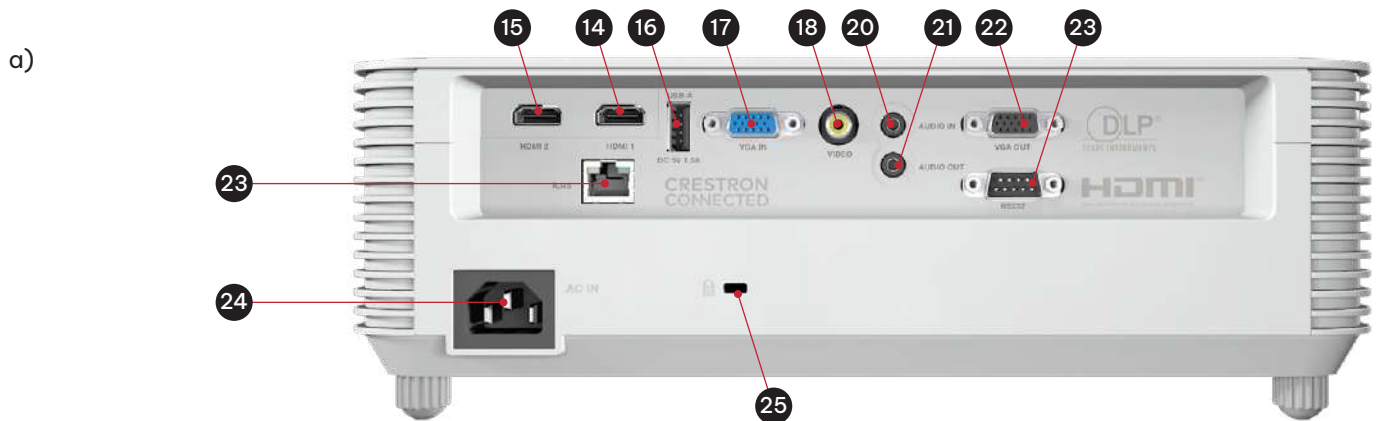

REGULATORY MODEL	SERIES NAME	LENS TYPE/ RESOLUTION	SVGA	XGA	WXGA	1080P
P122	INFOCUS LIGHTPRO VISTA II	STANDARD THROW	-	IN0044SL	IN0046SL	IN0048SL
P123	INFOCUS LIGHTPRO VISTA II	SHORT THROW	-	IN0024ST	IN0026ST	IN0028ST

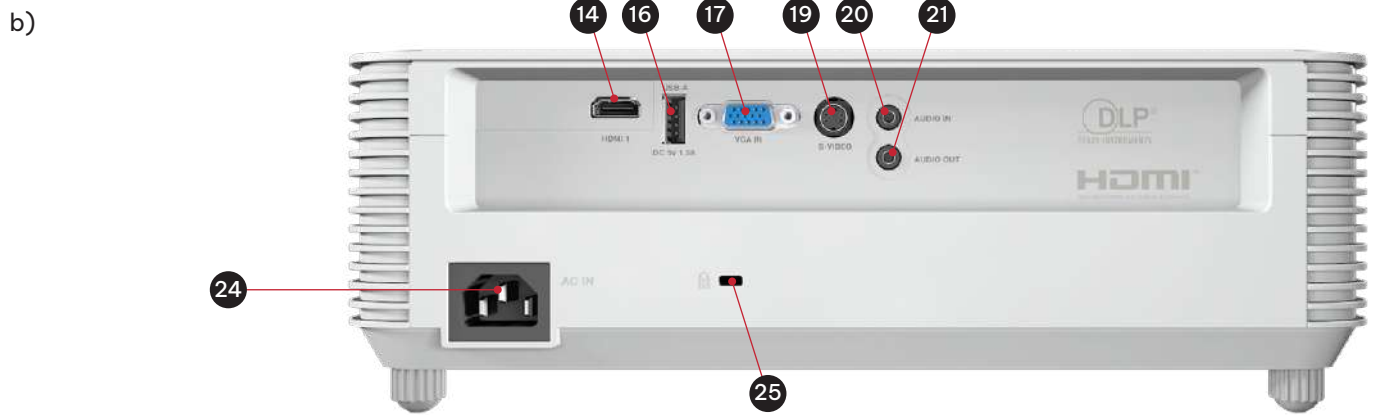

REGULATORY MODEL	SERIES NAME	LENS TYPE/ RESOLUTION	SVGA	XGA	WXGA	1080P
P124	INFOCUS LIGHTPRO GENESIS III	STANDARD THROW	IN0002SL	IN0004SL	IN0006SL	-

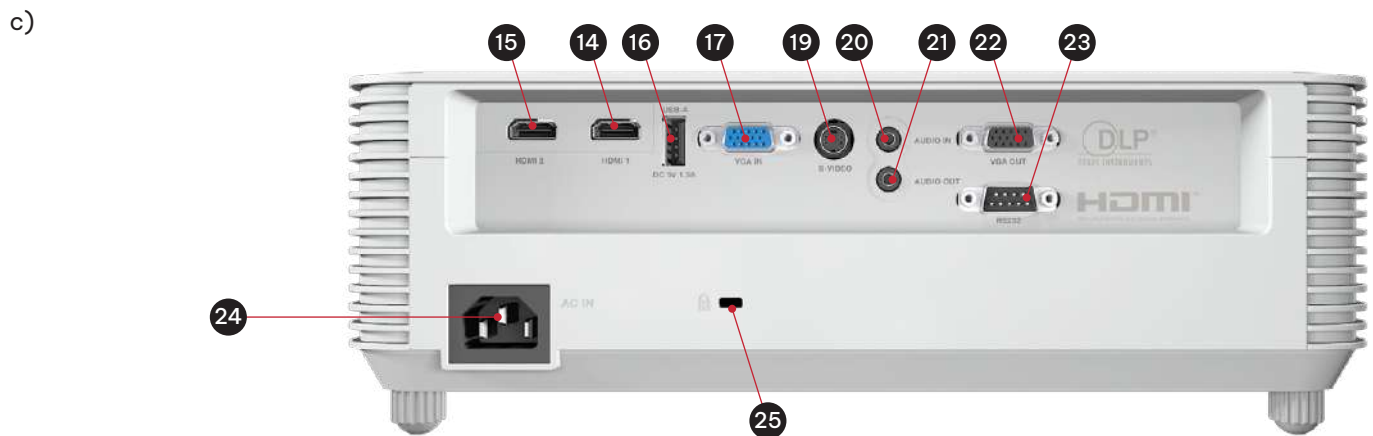

REGULATORY MODEL	SERIES NAME	LENS TYPE/ RESOLUTION	SVGA	XGA	WXGA	1080P
P125	INFOCUS LIGHTPRO GENESIS IV	STANDARD THROW	IN0022SL	IN0024SL	IN0026SL	IN0028SL
P126	INFOCUS LIGHTPRO GENESIS IV	SHORT THROW	-	IN0024ST	IN0026ST	-

REFERENCE	DESCRIPTION	REFERENCE	DESCRIPTION
1	Standard throw zoom lens	14	HDMI 1, 1.4 Input
2	Remote control IR receiver 1	15	HDMI 2, 1.4 Input
3	Adjustable feet	16	USB A for service and wireless dongle power 5v/1.5A
4	Air exhaust grill	17	VGA Input
5	Short throw fixed lens	18	Composite Input
6	Air Intake grill	19	S-VIDEO Input
7	Cable and Lock slot	20	3.5mm Audio Input
8	Focus adjustment ring	21	3.5mm Audio Output
9	Zoom adjustment ring	22	VGA Output
10	Keypad	23	RS232 Control
11	LED function lights	24	RJ45 Networking and Control
12	Lamp door	25	Power Cord AC IN
13	Remote control IR receiver 2	26	Kensington Lock Slot

## 3. SAFETY

### 3.1 HOW TO USE THE PRODUCT SAFELY



#### WARNING

Read and understand this guide and its safety instructions before using this product. Failure to do so can result in serious injury.

#### 3.1.1 VULNERABLE PEOPLE SAFETY INFORMATION

This device is not intended for use by persons (including children) with restricted physical, sensory or intellectual capability or lack of experience and/or knowledge.

The projector complies with the safety standards for electromagnetic devices. Contact your physician prior to use if you have a pacemaker or other implanted device.

#### 3.1.2 TECHNICAL LIFE SPAN

The technical lifespan of the projector is five years or 20,000 hours of use in normal mode and 30,000 hours of use in ECO mode under normal operating conditions (whichever comes first).

#### 3.1.3 INTENDED USE SAFETY INFORMATION

Use the projector only for its intended use as described in this user guide.  
Do not expose the projector to temperatures above 104 F / 40 C or below 32 F / 0 C.

#### 3.1.4 INSTALLATION SAFETY INFORMATION

Check the projector for damage before installation. If there is any visible damage, do not connect the projector and contact InFocus.

##### Do not install the projector:

- Near heat sources such as radiators, heat registers, stoves, or other devices that produce heat
- Near water or in direct sunlight
- In an enclosure such as a book case or a cabinet that restricts air flow

#### 3.1.5 ELECTRICAL SAFETY INFORMATION

Check for damage before connecting the power cable.  
Only connect the projector to a grounded socket with earth leakage protection using the provided power cable.

##### Immediately unplug the projector from the wall outlet:

- If it has been damaged
- If water or another substance enters the projector
- If you smell smoke or other odours coming from the projector
- During lightning storms
- When unused for long periods of time

#### 3.1.6 SAFETY INFORMATION



#### WARNING

Do not look straight at the projector lens during operation.  
The intense light beam may damage your eyes.

### 3.1.7 MAINTENANCE SAFETY INFORMATION

Review the instructions in the CLEANING section before cleaning the projector.  
 Disconnect the power supply before cleaning the projector. Do not use abrasive cleaning cloths or chemicals.

### 3.1.8 SERVICE AND REPAIR SAFETY INFORMATION









The projector contains no user serviceable parts. Contact InFocus for service or repair.

## 3.2 SAFE DISPOSAL

Follow the instructions in the DISPOSAL section in this user guide for safe disposal of the projector.

## 3.3 GRAPHICAL SYMBOLS

The following table describes the safety and regulatory symbols and marks on the packaging and product.

SYMBOL	DESCRIPTION
	The CCC mark on the product is the manufacturer's declaration that the product complies with the essential requirements for the relevant safety legislation of China.
	The CE mark on the product is the manufacturer's declaration that the product complies with the essential requirements of the relevant European health, safety, and environmental protection legislation.
	The cTUVus seal on a product is a seal of quality that confirms that the product has been tested by the German TÜV testing organization for use in the US and Canada.
	The EAC mark on the product is the manufacturer's declaration that the product complies with the essential requirements of the relevant safety legislation of the Eurasian Economic Union (EAEU).
	The FCC mark on the product is the manufacturer's declaration that the product's electromagnetic radiation is below the limits specified by the Federal Communication Commission (FCC).
	The NOM mark on the product is the manufacturer's declaration that the product complies with the essential requirements of the relevant Mexican safety legislation.
	The RoHS mark on the product is the manufacturer's declaration that the product complies with the essential requirements of the relevant European Union safety legislation.
	The Waste Electrical and Electronic Equipment (WEEE) symbol on the product, the accessories, or packaging indicates that this device shall not be treated as unsorted municipal waste, but shall be collected separately.
	The certification scheme of the Bureau of Indian Standards (BIS) is mandatory for specific electronic products in India. The BIS mark on the product is the manufacturer's declaration that the product complies with the essential requirements of the relevant India safety legislation.



## 4.1 PACKAGING CONTENTS

The projector packaging will contain:

- Projector
- Power cable
- VGA cable
- Remote control (batteries not included)
- Simplified users guide

## 4.2 INSTALLATION INSTRUCTIONS

Your projector is designed to be installed in one of four possible positions. Your room layout or personal preference will dictate which installation location you select. Take into consideration the size and position of your screen, the location of a suitable power outlet, as well as the location and distance between the projector and the rest of your equipment.

1. Table mounted front projection
2. Table mounted rear projection
3. Ceiling mounted front projection
4. Ceiling mounted rear projection

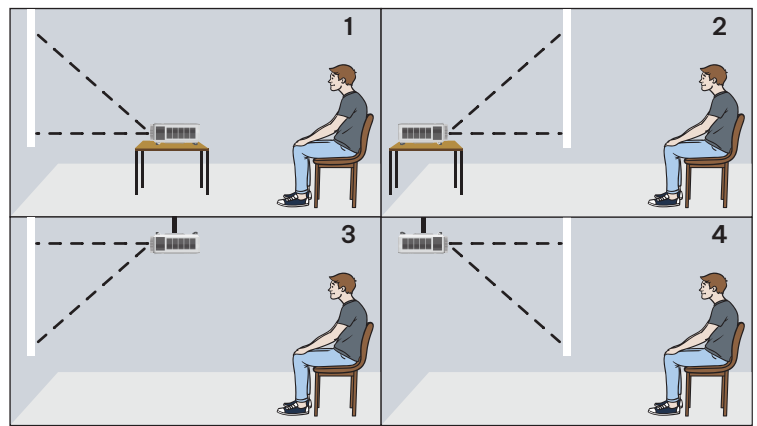

## 4.3 PLACEMENT AND DISTANCE FROM THE SCREEN

The projected image size will increase based on the projector's distance from the screen or projection surface. You can use the following tables to determine the best location for the projector and screen.

### 4.3.1 PROJECTION DISTANCE AND SCREEN SIZE

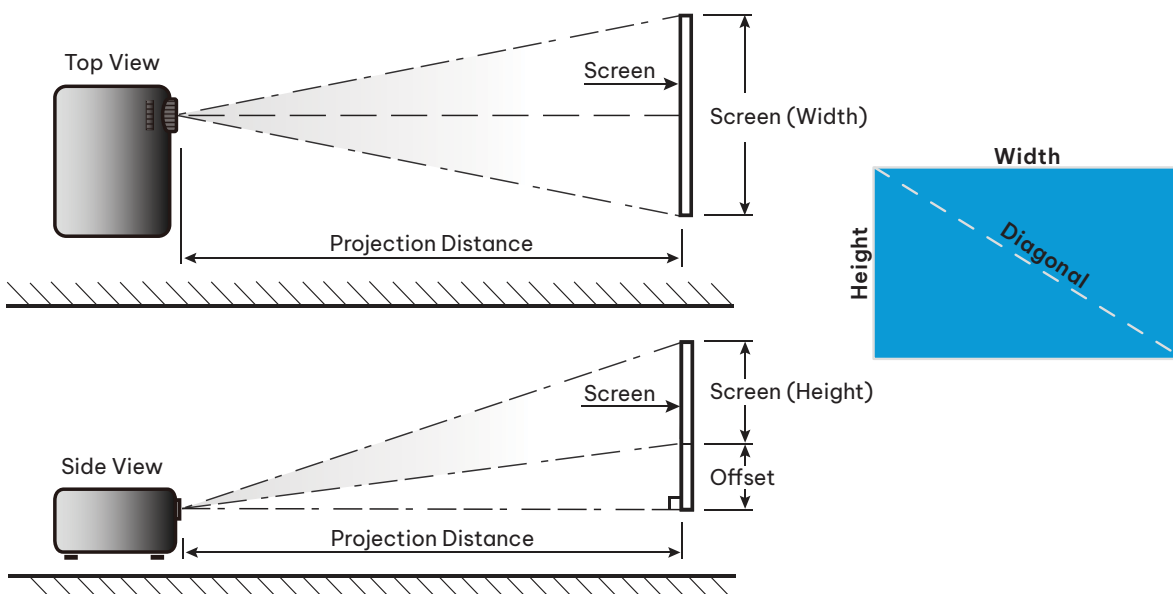

### IN0044SL\_RT\_XGA 1.3\* ZOOM

Diagonal Screen	Screen size				Projection distance				Offset	
	(m)		(inch)		(m)		(inch)		(cm)	(inch)
	Width	Hight	Width	Hight	Wide	Tele	Wide	Tele		
30	0,61	0,46	24,02	18,11	0,9	1,2	35,43	47,24	7	2,8
40	0,81	0,61	31,89	24,02	1,2	1,6	47,24	62,99	9	3,5
50	1,02	0,76	40,16	29,92	1,5	2,0	59,06	78,74	12	4,7
60	1,22	0,91	48,03	35,83	1,8	2,4	70,87	94,49	14	5,5
70	1,42	1,07	55,91	42,13	2,1	2,7	82,68	106,30	16	6,3
80	1,63	1,22	64,17	48,03	2,4	3,1	94,49	122,05	18	7,1
90	1,83	1,37	72,05	53,94	2,7	3,5	106,30	137,80	21	8,3
100	2,03	1,52	79,92	59,84	3,0	3,9	118,11	153,54	23	9,1
120	2,44	1,83	96,06	72,05	3,6	4,7	141,73	185,04	27	10,6
150	3,05	2,29	120,08	90,16	4,5	5,9	177,17	232,28	34	13,4
200	4,06	3,05	159,84	120,08	6,0	7,8	236,22	307,09	46	18,1
250	5,08	3,81	200,00	150,00	7,5	9,8	295,28	385,83	57	22,4
300	6,1	4,57	240,16	179,92	9,0	==	354,33	==	69	27,2

### IN0046SL\_RT\_WXGA 1.3\* ZOOM

Diagonal Screen	Screen size				Projection distance				Offset	
	(m)		(inch)		(m)		(inch)		(cm)	(inch)
	Width	Hight	Width	Hight	Wide	Tele	Wide	Tele		
30	0,65	0,4	25,59	15,75	0,8	1,0	31,5	39,4	5	1,97
40	0,86	0,54	33,86	21,26	1,0	1,3	39,4	51,2	7	2,76
50	1,08	0,67	42,52	26,38	1,3	1,7	51,2	66,9	9	3,54
60	1,29	0,81	50,79	31,89	1,5	2,0	59,1	78,7	10	3,94
70	1,51	0,94	59,45	37,01	1,8	2,3	70,9	90,6	12	4,72
80	1,72	1,08	67,72	42,52	2,0	2,7	78,7	106,3	13	5,12
90	1,94	1,21	76,38	47,64	2,3	3,0	90,6	118,1	15	5,91
100	2,15	1,35	84,65	53,15	2,6	3,3	102,4	129,9	16	6,30
120	2,58	1,62	101,57	63,78	3,1	4,0	122,0	157,5	20	7,87
150	3,23	2,02	127,17	79,53	3,8	5,0	149,6	196,9	25	9,84
200	4,31	2,69	169,69	105,91	5,1	6,7	200,8	263,8	34	13,39
250	5,38	3,37	211,81	132,68	6,4	8,3	252,0	326,8	41	16,14
300	6,46	4,04	254,33	159,06	7,7	==	303,1	==	52	20,47

**IN0048SL\_RT\_1080p 1.3\* ZOOM**

Diagonal Screen	Screen size				Projection distance				Offset	
	(m)		(inch)		(m)		(inch)		(cm)	(inch)
	Width	Hight	Width	Hight	Wide	Tele	Wide	Tele		
<b>30</b>	0,66	0,37	25,98	14,57	0,8	1	31,50	39,37	6	2,36
<b>40</b>	0,89	0,50	35,04	19,69	1	1,3	39,37	51,18	8	3,15
<b>50</b>	1,11	0,62	43,70	24,41	1,3	1,6	51,18	62,99	10	3,94
<b>60</b>	1,33	0,75	52,36	29,53	1,5	2	59,06	78,74	12	4,72
<b>70</b>	1,55	0,87	61,02	34,25	1,8	2,3	70,87	90,55	14	5,51
<b>80</b>	1,77	1,00	69,69	39,37	2	2,6	78,74	102,36	16	6,30
<b>90</b>	1,99	1,12	78,35	44,09	2,3	2,9	90,55	114,17	18	7,09
<b>100</b>	2,21	1,25	87,01	49,21	2,5	3,3	98,43	129,92	19	7,48
<b>120</b>	2,66	1,49	104,72	58,66	3	3,9	118,11	153,54	24	9,45
<b>150</b>	3,32	1,87	130,71	73,62	3,8	4,9	149,61	192,91	30	11,81
<b>200</b>	4,43	2,49	174,41	98,03	5	6,5	196,85	255,91	40	15,75
<b>250</b>	5,53	3,11	217,72	122,44	6,3	8,1	248,03	318,90	50	19,69
<b>300</b>	6,64	3,74	261,42	147,24	7,5	==	295,28	==	59	23,23

**IN0044ST\_ST\_XGA 1:1\* ZOOM**

Diagonal Screen	Screen size				Projection distance		Offset	
	(m)		(inch)		(m)	(inch)	(cm)	(inch)
	Width	Hight	Width	Hight	Wide	Wide		
<b>40</b>	0,81	0,61	32,01	24,02	0,5	19,69	9	3,54
<b>50</b>	1,02	0,76	40,00	30,00	0,63	24,80	11,8	4,65
<b>60</b>	1,22	0,91	47,99	35,98	0,75	29,53	13,6	5,35
<b>70</b>	1,42	1,07	55,98	42,01	0,88	34,65	16,3	6,42
<b>80</b>	1,63	1,22	64,02	47,99	1	39,37	18,1	7,13
<b>90</b>	1,83	1,37	72,01	54,02	1,13	44,49	20,8	8,19
<b>100</b>	2,03	1,52	80,00	60,00	1,25	49,21	22,6	8,90
<b>120</b>	2,44	1,83	95,98	72,01	1,5	59,06	27,1	10,67
<b>150</b>	3,05	2,29	120,00	90,00	1,88	74,02	34,4	13,54
<b>180</b>	3,66	2,74	144,02	107,99	2,26	88,98	40,7	16,02
<b>250</b>	5,08	3,81	200,00	150,00	3,13	123,23	57	22,44
<b>303</b>	6,16	4,62	242,40	181,81	3,8	149,61	69,2	27,24

### IN1056ST\_ST\_WXGA 1:1\* ZOOM

Diagonal Screen	Screen size				Projection distance		Offset	
	(m)		(inch)		(m)	(inch)	(cm)	(inch)
	Width	Hight	Width	Hight	Wide	Wide		
<b>40</b>	0,86	0,54	33,92	21,20	0,45	17,72	7,15	2,81
<b>50</b>	1,08	0,67	42,40	26,50	0,56	22,05	8,69	3,42
<b>60</b>	1,29	0,81	50,88	31,80	0,67	26,38	10,23	4,03
<b>70</b>	1,51	0,94	59,36	37,10	0,79	31,10	11,77	4,63
<b>80</b>	1,72	1,08	67,84	42,40	0,9	35,43	13,3	5,24
<b>90</b>	1,94	1,21	76,32	47,70	1,01	39,76	14,84	5,84
<b>100</b>	2,15	1,35	84,80	53,00	1,12	44,09	16,38	6,45
<b>120</b>	2,58	1,62	101,76	63,60	1,35	53,15	20,46	8,06
<b>150</b>	3,23	2,02	127,20	79,50	1,68	66,14	25,07	9,87
<b>180</b>	3,88	2,42	152,64	95,40	2,02	79,53	29,68	11,69
<b>250</b>	5,38	3,37	212,00	132,50	2,81	110,63	41,45	16,32
<b>302,9</b>	6,52	4,08	256,86	160,54	3,4	133,86	50,24	19,78

### IN0048ST\_ST\_1080p1:1\* ZOOM

Diagonal Screen	Screen size				Projection distance		Offset	
	(m)		(inch)		(m)	(inch)	(cm)	(inch)
	Width	Hight	Width	Hight	Wide	Wide		
<b>40</b>	0,89	0,50	34,86	19,61	0,44	17,32	8,19	3,22
<b>50</b>	1,11	0,62	43,58	24,51	0,55	21,65	9,74	3,83
<b>60</b>	1,33	0,75	52,30	29,42	0,66	25,98	12,28	4,83
<b>70</b>	1,55	0,87	61,01	34,32	0,77	30,31	13,83	5,44
<b>80</b>	1,77	1,00	69,72	39,22	0,88	34,65	16,38	6,45
<b>90</b>	1,99	1,12	78,44	44,12	0,99	38,98	17,93	7,06
<b>100</b>	2,21	1,25	87,16	49,03	1,10	43,31	19,47	7,67
<b>120</b>	2,66	1,49	104,59	58,83	1,32	51,97	23,57	9,28
<b>150</b>	3,32	1,87	130,74	73,54	1,65	64,96	30,21	11,89
<b>180</b>	3,98	2,24	156,88	88,25	1,98	77,95	35,85	14,11
<b>250</b>	5,53	3,11	217,89	122,57	2,75	108,27	49,68	19,56
<b>302,9</b>	6,71	3,77	264,00	148,50	3,33	131,10	60,81	23,94

**IN0002SL, IN000SL, IN0022SL, IN0024SL\_RT\_SVGA & XGA\_1.1\* ZOOM**

Diagonal Screen	Screen size				Projection distance				Offset	
	(m)		(inch)		(m)		(inch)		(cm)	(inch)
	Width	Hight	Width	Hight	Wide	Tele	Wide	Tele		
<b>30</b>	0,61	0,46	24,00	18,00	1,18	1,32	46,56	51,84	6,86	2,70
<b>40</b>	0,81	0,61	32,00	24,00	1,58	1,76	62,08	69,12	9,14	3,60
<b>50</b>	1,02	0,76	40,00	30,00	1,97	2,19	77,60	86,40	11,43	4,50
<b>60</b>	1,22	0,91	48,00	36,00	2,37	2,63	93,12	103,68	13,72	5,40
<b>70</b>	1,42	1,07	56,00	42,00	2,76	3,07	108,64	120,96	16,00	6,30
<b>80</b>	1,63	1,22	64,00	48,00	3,15	3,51	124,16	138,24	18,29	7,20
<b>90</b>	1,83	1,37	72,00	54,00	3,55	3,95	139,68	155,52	20,57	8,10
<b>100</b>	2,03	1,52	80,00	60,00	3,94	4,39	155,20	172,80	22,86	9,00
<b>120</b>	2,44	1,83	96,00	72,00	4,73	5,27	186,24	207,36	27,43	10,80
<b>150</b>	3,05	2,29	120,00	90,00	5,91	6,58	232,80	259,20	34,29	13,50
<b>200</b>	4,06	3,05	160,00	120,00	7,88	8,78	310,40	345,60	45,72	18,00
<b>250</b>	5,08	3,81	200,00	150,00	9,86	10,97	388,00	432,00	57,15	22,50
<b>300</b>	6,10	4,57	240,00	180,00	11,83	13,17	465,60	518,40	68,58	27,00

**IN006SL, IN0026SL\_RT\_WXGA\_1.1\* ZOOM**

Diagonal Screen	Screen size				Projection distance				Offset	
	(m)		(inch)		(m)		(inch)		(cm)	(inch)
	Width	Hight	Width	Hight	Wide	Tele	Wide	Tele		
<b>30</b>	0,65	0,40	25,44	15,90	1,00	1,11	39,18	43,76	5,01	1,97
<b>40</b>	0,86	0,54	33,92	21,20	1,33	1,48	52,24	58,34	6,68	2,63
<b>50</b>	1,08	0,67	42,40	26,50	1,66	1,85	65,30	72,93	8,35	3,29
<b>60</b>	1,29	0,81	50,88	31,80	1,99	2,22	78,36	87,51	10,02	3,94
<b>70</b>	1,51	0,94	59,36	37,10	2,32	2,59	91,41	102,10	11,68	4,60
<b>80</b>	1,72	1,08	67,84	42,40	2,65	2,96	104,47	116,68	13,35	5,26
<b>90</b>	1,94	1,21	76,32	47,70	2,99	3,33	117,53	131,27	15,02	5,91
<b>100</b>	2,15	1,35	84,80	53,00	3,32	3,70	130,59	145,86	16,69	6,57
<b>120</b>	2,58	1,62	101,76	63,60	3,98	4,45	156,71	175,03	20,03	7,89
<b>150</b>	3,23	2,02	127,20	79,50	4,98	5,56	195,89	218,78	25,04	9,86
<b>200</b>	4,31	2,69	169,60	106,00	6,63	7,41	261,18	291,71	33,39	13,14
<b>250</b>	5,38	3,37	212,00	132,50	8,29	9,26	326,48	364,64	41,73	16,43
<b>300</b>	6,46	4,04	254,40	159,00	9,95	11,11	391,78	437,57	50,08	19,72

### IN0028SL\_RT\_1080p\_1.1\* ZOOM

Diagonal Screen	Screen size				Projection distance				Offset	
	(m)		(inch)		(m)		(inch)		(cm)	(inch)
	Width	Hight	Width	Hight	Wide	Tele	Wide	Tele		
30	0,66	0,37	26,15	14,71	0,98	1,08	38,44	42,36	5,98	2,35
40	0,89	0,50	34,86	19,61	1,30	1,43	51,25	56,48	7,97	3,14
50	1,11	0,62	43,58	24,51	1,63	1,79	64,06	70,60	9,96	3,92
60	1,33	0,75	52,29	29,42	1,95	2,15	76,87	84,72	11,95	4,71
70	1,55	0,87	61,01	34,32	2,28	2,51	89,69	98,84	13,95	5,49
80	1,77	1,00	69,73	39,22	2,60	2,87	102,50	112,96	15,94	6,28
90	1,99	1,12	78,44	44,12	2,93	3,23	115,31	127,08	17,93	7,06
100	2,21	1,25	87,16	49,03	3,25	3,59	128,12	141,20	19,92	7,84
120	2,66	1,49	104,59	58,83	3,91	4,30	153,75	169,43	23,91	9,41
150	3,32	1,87	130,74	73,54	4,88	5,38	192,18	211,79	29,89	11,77
200	4,43	2,49	174,32	98,05	6,51	7,17	256,24	282,39	39,85	15,69
250	5,53	3,11	217,89	122,57	8,14	8,97	320,30	352,99	49,81	19,61
300	6,64	3,74	261,47	147,08	9,76	10,76	384,36	423,59	59,77	23,53

### IN0024ST\_ST\_XGA\_Fixed Lens

Diagonal Screen	Screen size				Projection distance		Offset	
	(m)		(inch)		(m)	(inch)	(cm)	(inch)
	Width	Hight	Width	Hight	Wide	Wide		
30	0,61	0,46	24,00	18,00	0,32	12,48	5,67	2,23
40	0,81	0,61	32,00	24,00	0,42	16,64	7,56	2,98
50	1,02	0,76	40,00	30,00	0,53	20,80	9,45	3,72
60	1,22	0,91	48,00	36,00	0,63	24,96	11,34	4,46
70	1,42	1,07	56,00	42,00	0,74	29,12	13,23	5,21
80	1,63	1,22	64,00	48,00	0,85	33,28	15,12	5,95
90	1,83	1,37	72,00	54,00	0,95	37,44	17,01	6,70
100	2,03	1,52	80,00	60,00	1,06	41,60	18,90	7,44
120	2,44	1,83	96,00	72,00	1,27	49,92	22,68	8,93
150	3,05	2,29	120,00	90,00	1,58	62,40	28,35	11,16
200	4,06	3,05	160,00	120,00	2,11	83,20	37,80	14,88
250	5,08	3,81	200,00	150,00	2,64	104,00	47,24	18,60
300	6,10	4,57	240,00	180,00	3,17	124,80	56,69	22,32

**IN0026ST\_ST\_WXGA\_Fixed Lens**

Diagonal Screen	Screen size				Projection distance		Offset	
	(m)		(inch)		(m)	(inch)	(cm)	(inch)
	Width	Hight	Width	Hight	Wide	Wide		
<b>30</b>	0,65	0,40	25,44	15,90	0,34	13,23	5,01	1,97
<b>40</b>	0,86	0,54	33,92	21,20	0,45	17,64	6,68	2,63
<b>50</b>	1,08	0,67	42,40	26,50	0,56	22,05	8,35	3,29
<b>60</b>	1,29	0,81	50,88	31,80	0,67	26,46	10,02	3,94
<b>70</b>	1,51	0,94	59,36	37,10	0,78	30,87	11,68	4,60
<b>80</b>	1,72	1,08	67,84	42,40	0,90	35,28	13,35	5,26
<b>90</b>	1,94	1,21	76,32	47,70	1,01	39,69	15,02	5,91
<b>100</b>	2,15	1,35	84,80	53,00	1,12	44,10	16,69	6,57
<b>120</b>	2,58	1,62	101,76	63,60	1,34	52,92	20,03	7,89
<b>150</b>	3,23	2,02	127,20	79,50	1,68	66,14	25,04	9,86
<b>200</b>	4,31	2,69	169,60	106,00	2,24	88,19	33,39	13,14
<b>250</b>	5,38	3,37	212,00	132,50	2,80	110,24	41,73	16,43
<b>300</b>	6,46	4,04	254,40	159,00	3,36	132,29	50,08	19,72

### 4.4 CLEARANCE

Allow at least 30cm clearance around the intake and exhaust vent and ensure that the intake vents do not recycle hot air from the exhaust vent.

REFERENCE	DESCRIPTION
1	Air intake vent
2	Air outtake vent

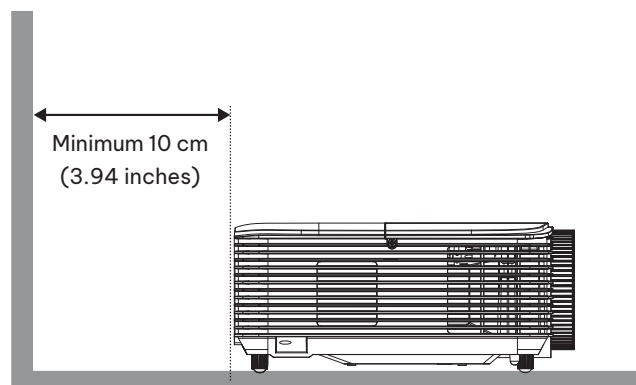
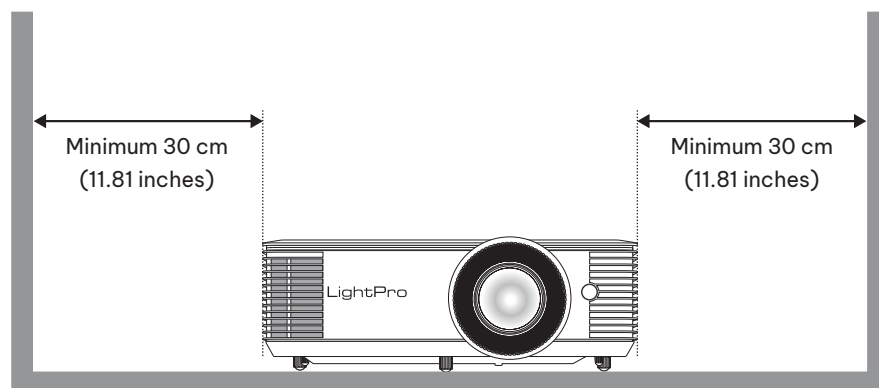
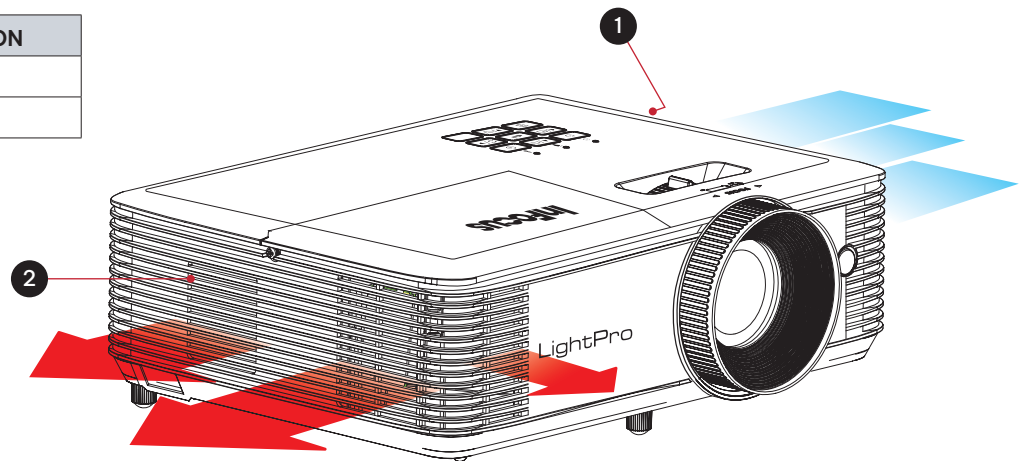



When operating the projector in an enclosed space:

- The surrounding air temperature within the enclosure should not exceed operation temperature while the projector is running
- The air intake and exhaust vents should be unobstructed
- The enclosure should pass a certified thermal evaluation to ensure that the projector does not recycle exhaust air

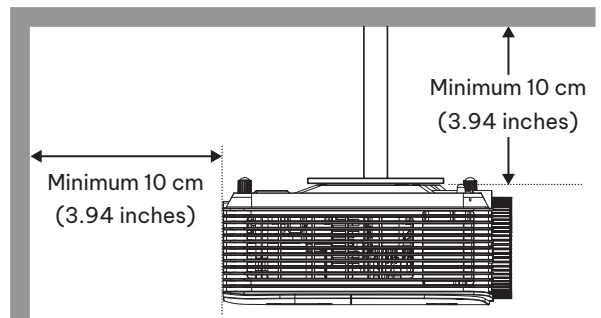

## 4.5 CEILING MOUNT

- Screw type: M4×10
- Minimum screw length: 10mm

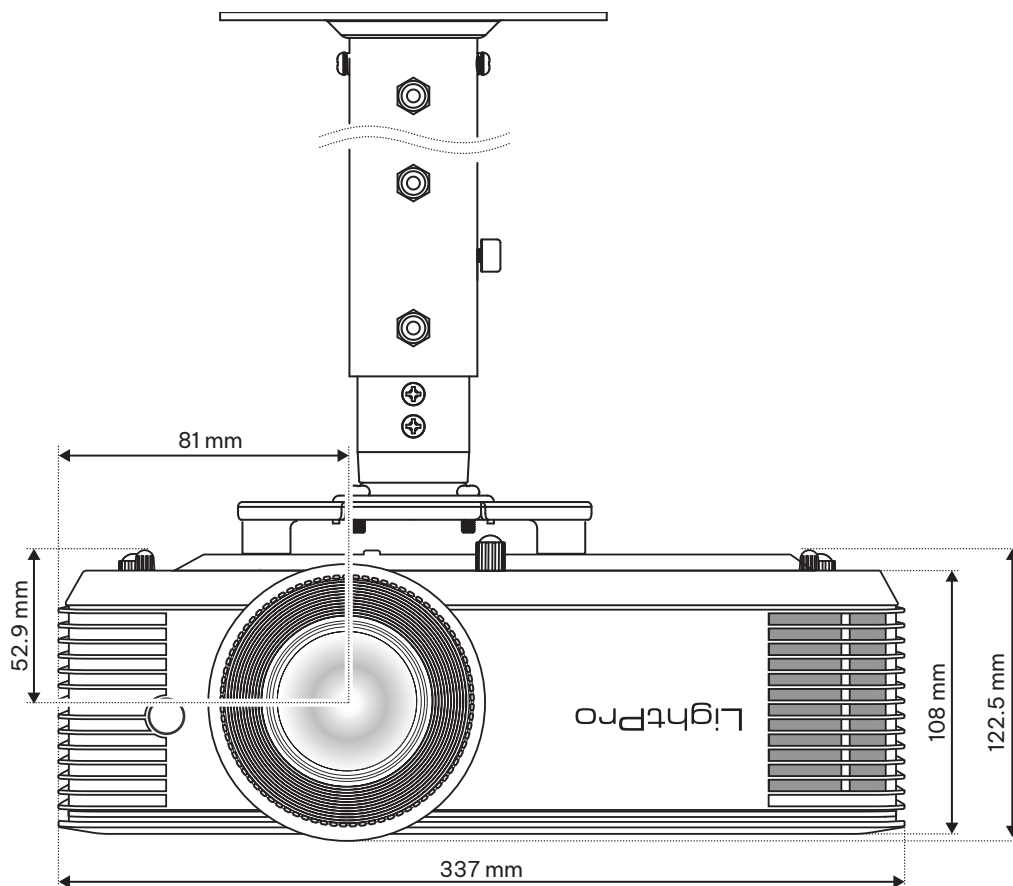

### INFORMATION

Please note that damage resulting from incorrect installation will void the warranty. If you buy a ceiling mount from another company, please be sure to use the correct screw size. Screw size will vary depending on the thickness of the mounting plate.

### 4.6 MOUNTING HOLE DIAGRAM

When using a ceiling mount, please be sure to use the correct screw size. Screw size will vary depending on the thickness of the mounting plate.

Be sure to keep at least 10 cm gap between the ceiling and the bottom of the projector.

Avoid installing the projector near a heat source.

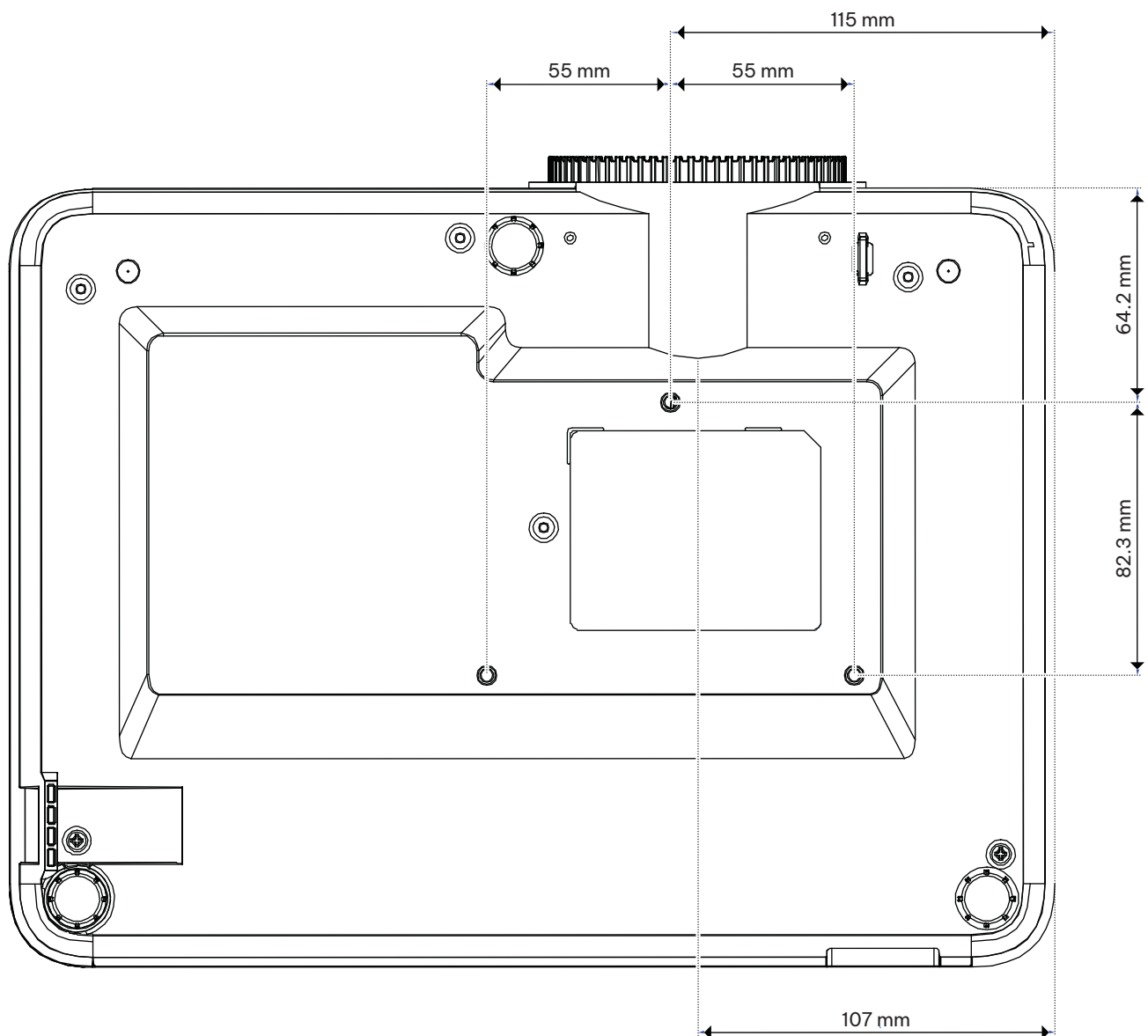

## 5. ADJUSTING

### 5.1 ADJUSTING THE IMAGE HEIGHT AND TILT

The projector's height and tilt can be adjusted with the tilt adjustment feet and ring. Locate the adjustable foot you wish to adjust on the underside of the projector. Rotate the foot clockwise or counterclockwise to raise or lower the projector.

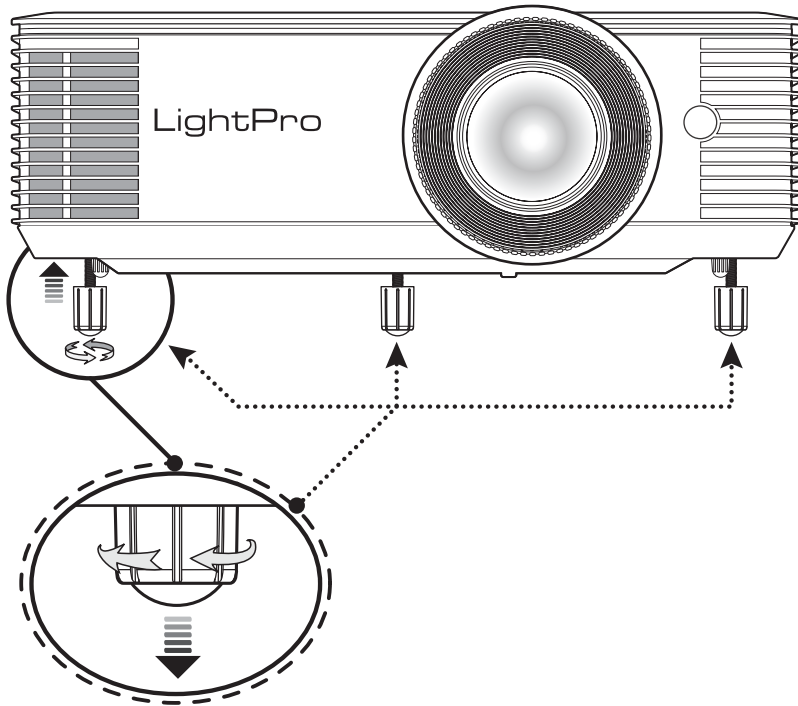

### 5.2 ADJUSTING THE ZOOM, LENS SHIFT AND FOCUS

To adjust the image size, turn the zoom ring clockwise or counterclockwise to increase or decrease the projected image size.

To adjust the image position, turn the lens shift dial clockwise or counterclockwise to adjust the position of the projected image vertically. (Not available on all models.)

To adjust the focus, turn the focus ring clockwise or counterclockwise until the image is sharp and legible.

### 5.3 ADJUSTING THE VERTICAL AND HORIZONTAL KEystone

If one side of the image is shorter than the other, for example the top is shorter than the bottom, you can either reposition the projector or use keystone correction.

To adjust the top or bottom of the picture (the pitch), angle the projector lower or higher. If that is not possible, adjust the vertical keystone:

Press the Menu button on the projector keypad or the Menu button on the remote control to open the OSD menu.

#### Select Image > V Keystone

Adjust the settings by using the arrow keys keys

Press the Return symbol or Enter button to select a setting.

Press the Menu symbol or \*Menu \*button to close the OSD menu. The menu will close and the projector will automatically save the new settings.

To adjust the left or right side of the picture (the yaw), turn the projector slightly left or right. If that is not possible, adjust the horizontal keystone:

Press the Menu button on the projector keypad or the Menu button on the remote control to open the OSD menu.

Select **\*Image > H Keystone \***

**Note** horizontal keystone correction is not available on all models

Adjust the settings by using the **\*Arrow \***keys.

Press press the Return symbol or **\*Enter \***button to select a setting.

Press the Menu button to close the OSD menu. The menu will close and the projector will automatically save the new settings.



### INFORMATION

Ensure that the projection screen or projection surface is within the required distance from the projector. Refer to “4.3 Placement distance from screen” for more information.

# 6. CONNECTING

## 6.1 CONNECTION DIAGRAM

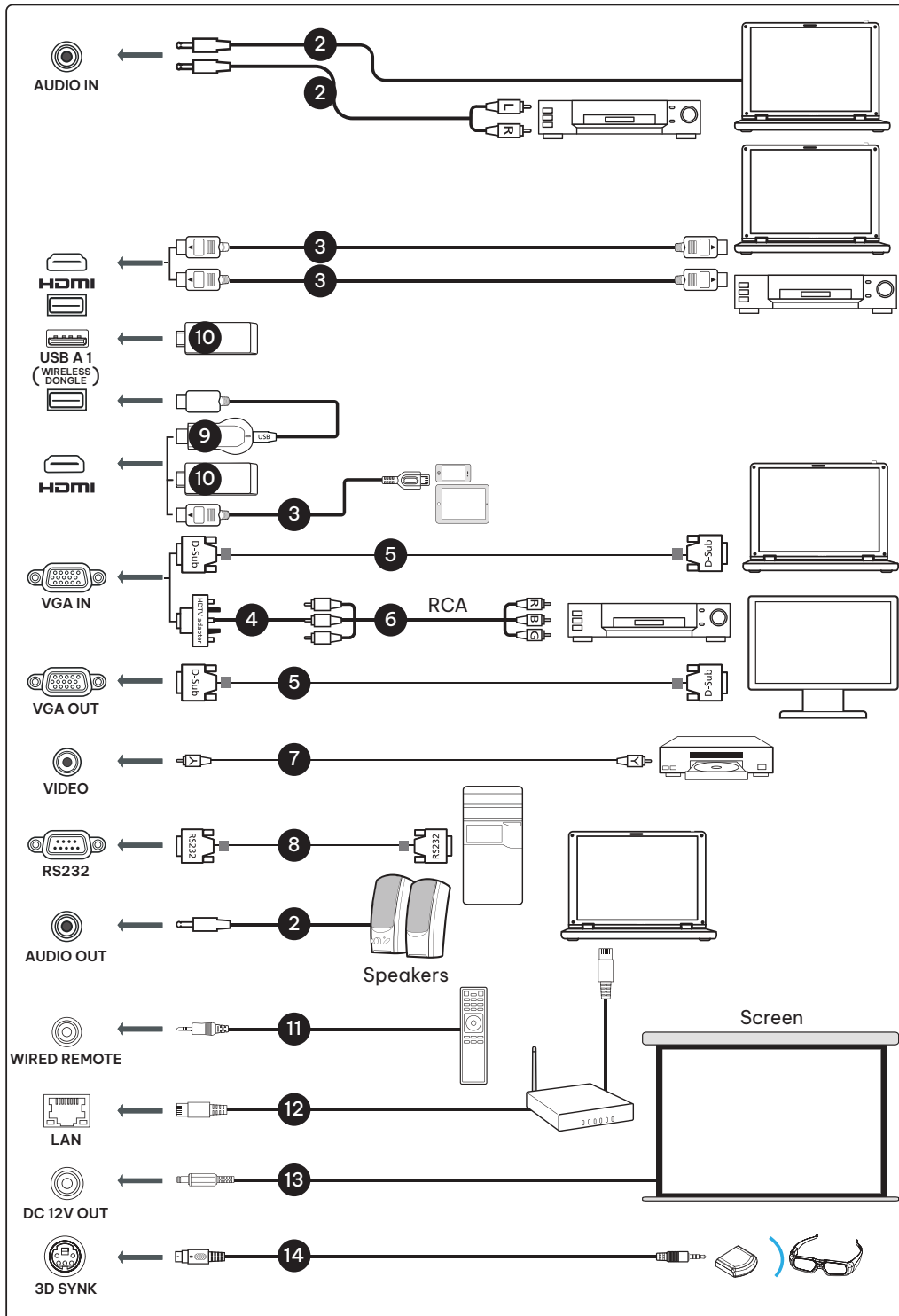

REFERENCE	DESCRIPTION	REFERENCE	DESCRIPTION
1	Power cord	8	RS232 cable
2	Audio cable	9	WirelessHD dongle
3	HDMI (MHL) cable	10	Wireless dongle
4	VGA to component/HDTV adapter	11	Wired remote control
5	VGA cable	12	LAN cable
6	3 RCA component cable	13	12V DC cable
7	Composite video cable	14	3D SYNC cable



### INFORMATION

Not all inputs are available on all models.

## 7. USING

### 7.1 LEDS

REFERENCE	DESCRIPTION
1	Power
2	Lamp
3	Temperature

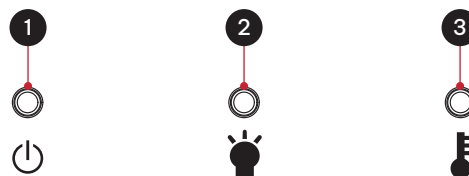

### 7.2 KEYPAD

REFERENCE	DESCRIPTION
1	Up / Keystone correction +
2	Information
3	Right / Re-sync
4	Enter
5	PowerDown / Keystone correction -
6	Menu
7	Directional arrows
8	Left / Source
9	Power

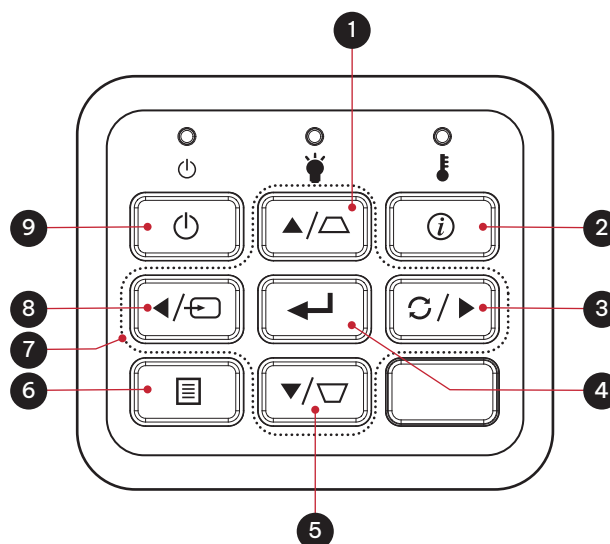

### 7.3 KEYPAD

REFERENCE	DESCRIPTION
1	IR LED
2	Power
3	Source
4	Enter
5	ECO
6	Volume
7	Aspect
8	HDMI – Press once for HDMI 1 and twice for HDMI 2
9	Zoom
10	Mute
11	Freeze
12	Picture
13	Mouse
14	Page
15	VGA
16	Video
17	Keystone correction
18	Menu
19	Directional keys
20	Re-sync
21	AV Mute

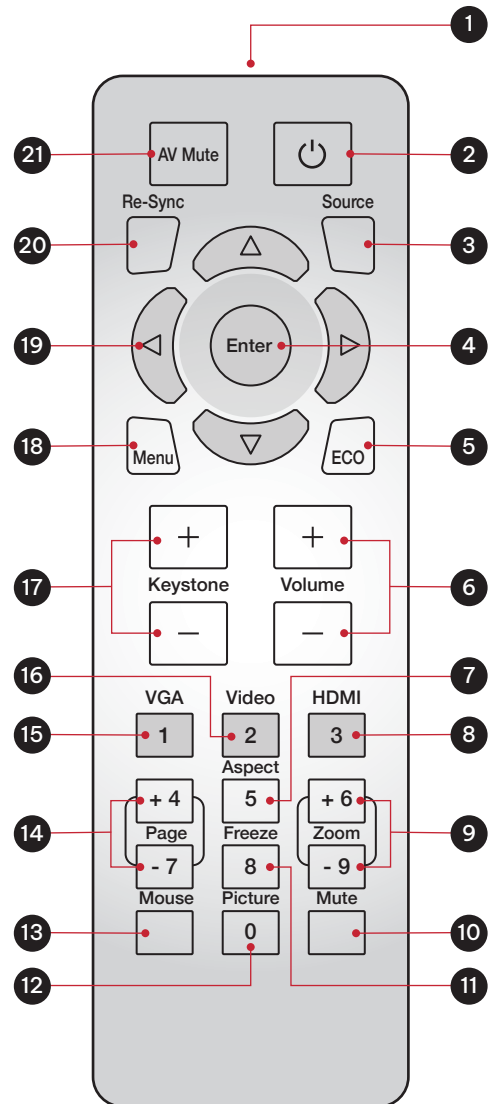

**INFORMATION**

Some keys may have no function for models that do not support the key's feature.

## 7.3.1 INSTALLING BATTERIES IN THE REMOTE CONTROL

The remote requires two AAA batteries (not included).

1. Remove the battery cover on the back of the remote control.

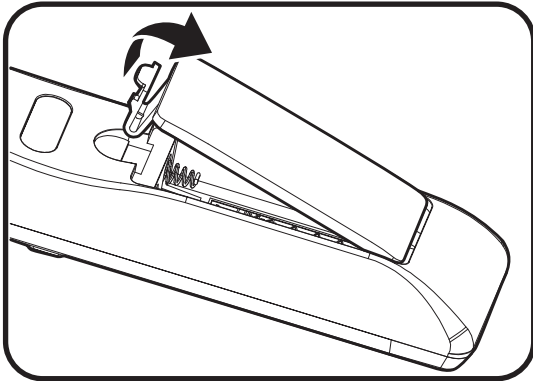

2. Insert AAA batteries in the battery compartment. Ensure each battery's polarity  $\pm$  is aligned correctly.

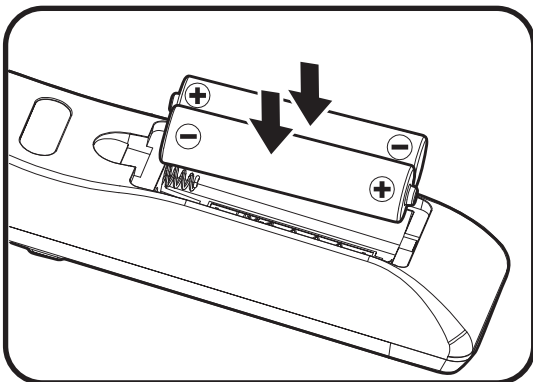

3. Replace back cover on the remote control and press down until it clicks in to place.

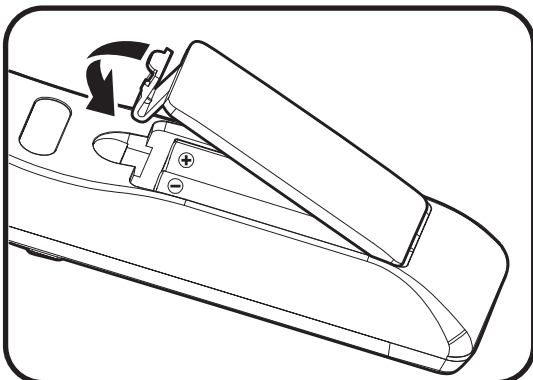

### ATTENTION

The remote control may fail to operate if the infrared remote sensor is exposed to bright sunlight or fluorescent lighting.

Incorrect battery usage may cause leakage of battery fluid and battery rupture, which could result in fire, injury or corrosion of the remote. When replacing batteries, take the following precautions.

**Do not use batteries of different types or mix old and new batteries.**

**Remove the batteries if you will not be using the projector for a long period of time.**

**Do not expose batteries to heat or flame and do not put them in water.**

**Dispose of used batteries according to local regulations.**

**Keep batteries out of the reach of children. Batteries are choking hazards and are very dangerous if swallowed.**



### 7.3.2 REMOTE CONTROL IR CODES

NUMBER	FUNCTION	REPEATFORMAT	BYTE1	BYTE2	BYTE3	BYTE4	COMMENTS
1	AV mute	F1	87	4E	51	AE	
2	Power On/Off	F1	87	4E	17	E8	
3	Re-Sync	F1	87	4E	33	CC	
4	Up	F2	87	4E	13	EC	Do Volume+ when no OSD
5	Source	F1	87	4E	10	EF	
6	Left	F2	87	4E	11	EE	Do Source when no OSD
7	Enter	F1	87	4E	32	CD	
8	Right	F2	87	4E	12	ED	Do Re-Sync when no OSD
9	Menu	F1	87	4E	02	FD	
10	Down	F2	87	4E	14	EB	Do Volume- when no OSD
11	Eco	F1	87	4E	77	88	Open Brightness Mode menu
12	Keystone+	F2	87	4E	20	DF	
13	Volume+	F2	87	4E	08	F7	
14	Keystone-	F2	87	4E	21	DE	
15	Volume-	F2	87	4E	04	FB	
16	VGA (1)	F1	87	4E	19	E6	
17	Video (2)	F1	87	4E	1A	E5	
18	HDMI (3)	F1	87	4E	71	8E	Toggle HDMI 1 and HDMI 2
19	Page+ (4)	F1	87	4E	7D	82	Page+ not supported
20	Aspect (5)	F1	87	4E	34	CB	
21	Zoom+	F1	87	4E	52	AD	
22	page- (7)	F1	87	4E	7E	81	Page- not supported
23	Freeze	F1	87	4E	0E	F1	
24	Zoom-	F1	87	4E	53	AC	
25	Mouse	F1	87	4E	3E	C1	Mouse not supported
26	Picture	F1	87	4E	2C	D3	Open Display Mode menu
27	Mute	F1	87	4E	29	D6	

### 7.4 REMOTE CONTROL EFFECTIVE RANGE

You can locate the infrared (IR) remote control sensors on the top of the projector next to the keypad and on the front to the left of the lens. Hold the remote control at an angle within 60 degrees perpendicular of the projector's IR remote control sensor. Ensure that there are no obstacles between the remote control and the IR sensor on the projector.

The distance between the remote control and the IR sensor should be less than 12 meters (39.4 feet). If the remote control is less than 20cm (8 inches) from the IR sensor, the remote control might become ineffective. The effective range is approximately 5 meters (16.4 feet) when reflecting the IR beam using a screen. The range will depend on the screen's surface and reflectivity. Direct sunlight or florescent lamps can reduce the range of the remote control.

## 7.5 TURNING THE PROJECTOR ON

1. Securely connect the mains cable to the projector and to a mains outlet. When connected, the Power LED will turn red.
2. Connect a signal/source cable to a source device and the projector.
3. Remove the lens cap.
4. Press the **Power** button on the keypad or the  symbol on the remote control.

The InFocus startup screen will appear after approximately 10 seconds. The Power LED will flash blue and then steady blue.



### ATTENTION

**Make sure that people cannot step on any electrical cables or trip over the cables. Do not put objects on the cables.**

## 7.6 SELECTING A INPUT SOURCE

1. Turn on the connected source, such as a computer or DVD player, or connect a digital media player, such as a Google Chromecast.
2. Press the Source button on the keypad or remote control to select the input source.
3. Play the content on the source device.



### INFORMATION

**You can set up the projector to automatically detect an active source and turn itself on and project the source content automatically. To turn on this feature, press the Menu button on the remote control or keypad, navigate to Settings > Power Settings > Signal Power, and select On.**



### INFORMATION

**Your projector has a Direct Power On setting. This setting will automatically turn on the projector when a power source is connected. To turn on this feature, press the Menu button on the remote control or keypad, navigate to Settings > Power Settings > Direct Power On, and select on.**

## 7.7 TURNING THE PROJECTOR TO STANDBY MODE

1. Press the **Power** button on the keypad or remote control.  
The following message will appear: Power Off?
2. Press the **Power** button again to confirm turning off your projector.  
If the **Power** button is not pressed a second time, the message will disappear after 10 seconds and the projector will not turn off.  
The cooling fans will operate for about 10 seconds and the Power LED will flash blue. When the Power LED changes to solid red, the projector has entered standby mode.
3. Replace the lens cap.



### INFORMATION

**If you want to turn the projector on again, wait 100 seconds.**

Always allow the projector fan to turn off after you power down and before you unplug the projector power cable from the electrical outlet.

## 7.8 VIEWING 3D CONTENT

Please follow all warnings and precautions as recommended before you or your child use the 3D function of this projector and view 3D projected content.



### ATTENTION

**Children and teenagers may be more susceptible to health issues associated with viewing in 3D and should be closely supervised when viewing 3D content.**

### 7.8.1 PHOTSENSITIVE SEIZURE WARNING AND OTHER HEALTH RISKS



### ATTENTION

- **Some viewers may experience an epileptic seizure or stroke when exposed to specific flashing images or lights contained in certain Projector pictures or video games. If you suffer from or have a family history of epilepsy or strokes, please consult with a medical specialist before using the 3Dfunction.**
- **Even those without a personal or family history of epilepsy or stroke may have an undiagnosed condition that can cause photosensitive epileptic seizures.**
- **We recommend that the projectors 3D functionality not be used by pregnant women, sufferers of serious medical conditions, persons who are sleep-deprived or under the influence of alcohol.**
- **If you experience any of the following symptoms, stop viewing 3D content immediately and consult a medical specialist: (1) altered vision; (2) lightheadedness; (3) dizziness; (4) involuntary movements such as eye or muscle twitching; (5) confusion; (6) nausea; (7) loss of awareness; (8) convulsions; (9) cramps; or (10) disorientation. Children and teenagers may be more likely than adults to experience these symptoms. Parents should monitor their children and ask whether they are experiencing these symptoms.**
- **Watching 3D projected content may also cause motion sickness, perceptual aftereffects, disorientation, eye strain, and decreased postural stability. Users should take frequent breaks to lessen the potential of these effects. If you have any of the above symptoms, immediately discontinue using this device and do not resume using it for at least thirty minutes after the symptoms have subsided.**
- **Watching 3D projected content while sitting too close to the screen for an extended period may damage your eyesight. The ideal viewing distance should be at least three times the screen height. We recommend that the viewer's eyes are level with the screen.**
- **Watching 3D projected content while wearing 3D glasses for an extended period may cause headaches or fatigue. If you experience a headache, tiredness or dizziness, stop viewing the 3D projection and rest.**
- **Do not use 3D glasses for any other purpose than for watching 3D projected content.**
- **Wearing the 3D glasses for any other purpose (such as spectacles, sunglasses, protective goggles, etc.) may be physically harmful to you and weaken your eyesight.**
- **Viewing 3D projected content may cause disorientation for some viewers. Accordingly, DO NOT place your 3D projector near open stairwells, cables, balconies, or other objects that can be tripped over, run into, knocked down, broken or fallen over.**

## 7.8.2 ENABELING 3D MODE

To enable 3D mode, the input frame rate should be set to 60Hz. Other frame rate are not supported. For the best 3D performance, use a resolution of 1920×1080. 4K (3840×2160) resolution is not supported in 3D mode.

1. Select **Display > Display Mode > 3D > 3D Mode**.
2. Select\* **On**\*.  
If the 3D Mode is set to Off, the 2D-3D and 3D sync Invert functions will not be selectable. These functions can only be selected if the 3D mode is set to On.
3. Press **Enter**.
4. If you only want to view the left or right frame: \* Select **Display > Display Mode > 3D > 3D-2D**. \* Select **L** (left) or **R** (right). \* Press **Enter**.
5. If you want to turn off the 3D sync invert function:
  - Select **Display > Display Mode > 3D > 3D Sync Invert**.
  - Select **Off**.
  - Press **Enter**.

## 7.8.3 ENABLING AUTO 3D MODE

1. Select **Display > Display Mode > 3D > 3D Format**.
2. Select **Auto**.
3. Press **Enter**.

Other options:

- SBS: Display 3D signal in “Side-by-Side” format.
- Top and Bottom: Display 3D signal in “Top and Bottom” format.
- Frame Sequential: Display 3D signal in “Frame Sequential” format.

## 8. USING THE ON SCREEN DISPLAY (OSD)

The multilingual On Screen Display (OSD) menus can be used to setup and adjust the projector.

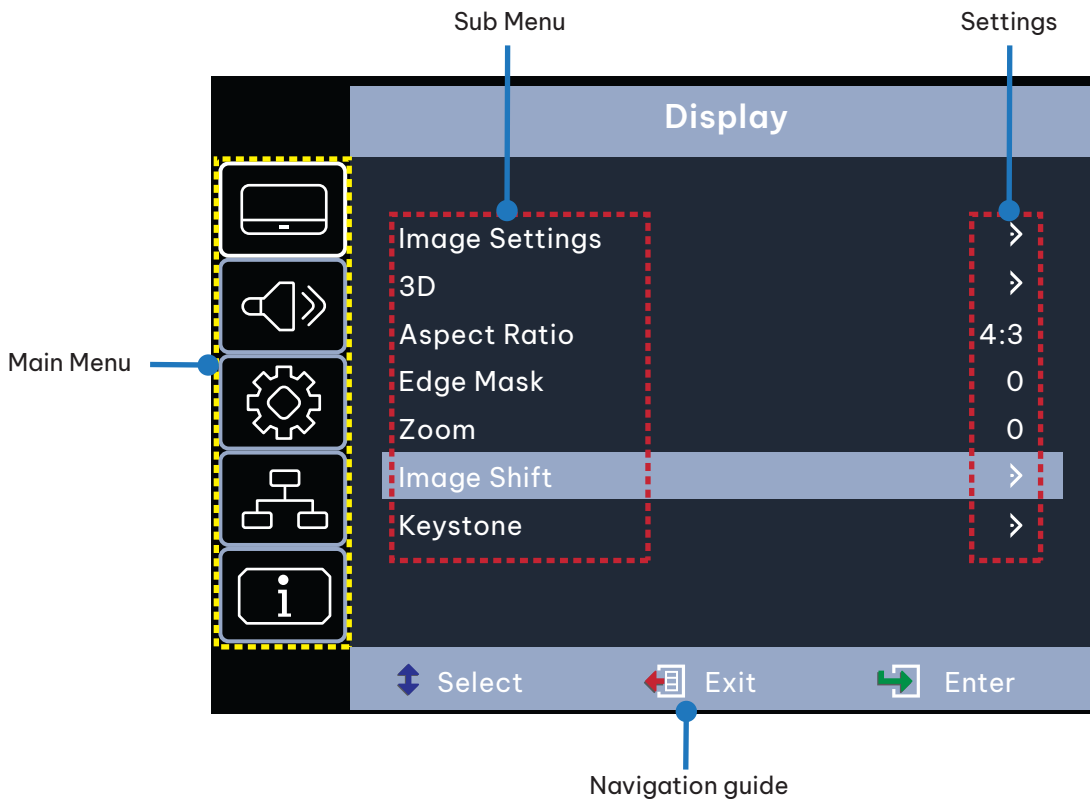

### 8.1 SELECTING THE LANGUAGE FOR THE ON SCREEN MENU

1. Select **Setup > Options > Language**
2. Select a language.
3. Press **Enter**.

### 8.2 SELECTING A DISPLAY MODE

1. Select **Display > Image Settings > Display Mode**.
2. Select a display mode:
  - **Presentation**: Suitable for giving presentations using a PC.
  - **Bright**: The brightest possible setting when using a PC.
  - **HDR SIM.**: Decodes and displays High Dynamic Range (HDR) content for the deepest blacks, brightest whites, and vivid cinematic colour using the REC.2020 colour gamut. This mode will be automatically enabled if HDR content is sent to the projector (4K UHD Blu-ray, 1080p/4K UHDHDR/HLG games, or 4K UHD streaming video). While HDR mode is active, other displays cannot be selected as HDR delivers colour that is highly accurate and exceeds the colour performance of the other display modes. HDR mode can also be manually selected for use with non HLG content for simulation effect.
  - **HLG SIM.**: Decodes and displays Hybrid Log Gamma (HLG) content for the deepest blacks, brightest whites, and vivid cinematic colour using the REC.2020 colour gamut. This mode will be automatically enabled if HLG content is sent to the projector (4K UHD Blu-ray, 1080p/4K UHDHDR/HLG games, or 4K UHD streaming video). HLG mode can also be manually selected for use with non HLG content for simulation effect.
  - **Cinema**: Provides the best colour reproduction for watching movies.

- Game: Increases the brightness and decreases the response time for playing video games with minimal lag.
- sRGB: Standardized accurate colour reproduction.
- DICOM SIM.: Simulation mode for viewing monochrome images such as X-rays.
- User: Saved user settings.
- 3D: To experience 3D, you will need 3D glasses and a video source that is capable of sending 3D content.

3. Press **Enter**.



### INFORMATION

The display settings are only visible when an active source is connected to the projector.

## 8.3 ADJUSTING THE IMAGE COLOUR AND TEMPERATURE

1. Select **Display > Image Settings > Color Settings > Color Temperature**.
2. Select a value.
3. Press **Enter**.



### INFORMATION

The display settings are only visible when an active source is connected to the projector.

## 8.4 ADJUSTING THE SHARPNESS OF THE IMAGE

1. Select **Display > Image Settings > Color**.
2. Press **Enter**.

## 8.5 MAGNIFYING THE IMAGE

1. Select **Display > Zoom**.
2. Press **Enter**.

## 8.6 SELECTING AN ASPECT RATIO

1. Select **Display > Aspect Ratio**.
2. Select the desired aspect ratio.
3. Press **Enter**.

## 8.7 ADJUSTING THE BRIGHTNESS

1. Select **Display > Image Settings > Brightness Mode**.
2. Select a brightness mode.
3. Press **Enter**.

## 8.8 ENABELING ECO MODE

1. Select **Display > Image Settings > Brightness Mode**.
2. Select **Eco**.
3. Press **Enter**.

## 8.9 ENABLING CLOSED CAPTIONS

1. Select **Setup > Options > Closed Caption**.
2. Select **CC1** \*or \***CC2**.
3. Press **Enter**.

## 8.10 DISPLAYING A TEST PATTERN

1. Select **Setup > Test Pattern**.
2. Select a test pattern.
3. Press **Enter**.

## 8.11 PREVENTING UNAUTHORIZED USE

1. Select **Setup \* > \*Security > Security**.
2. Select **\* On\***. The default password is 1234.
3. Press **Enter**.

## 8.12 CHANGING THE PASSWORD

1. Select **Setup > Security > Change Password**.
2. Type the new password.
3. Press **Enter**.



### INFORMATION

Do not lose the password. The password can only be reset at an authorized InFocus repair facility.

## 8.13 CONTROLLING THE PROJECTOR FROM A WEB BROWSER

1. Connect the projector to an active network port using the RJ45 port on the back of the projector.
2. Select\* **Network\*** > **LAN** > **DHCP**.
3. Select **On**.
4. Press **Enter**.
5. Select **Network** > **LAN** > **IP Address\*** to view the projector's IP address.
6. Open a web browser.
7. Type the projector's IP address type the user name and password. The default user name and password is admin.
8. Click **Login**. The projector's configuration page appears.



### INFORMATION

This section is only applicable to p122 and p123 Vista II products.





Web Control Aspect Ratio Support list below

Aspect Ratio	XGA	WXGA	1080P
4:3	✓	✓	✓
16:9	✓	✓ (Follow OSD->Screen Type)	✓
16:10		✓ (Follow OSD->Screen Type)	
LBX		✓	✓
Native	✓	✓	✓
AUTO	✓	✓	✓

**Notice** If web page select the unupport aspect ratio, projector will do nothing and the web will show the aspect ratio same with OSO.

The aspect ratio of WXGA model will change dueto the screen type setting.

[Logout](#)

**Admin > Network Setup**

IP Setup	DHCP <input type="radio"/> On <input checked="" type="radio"/> Off				
	IP Address	192	168	0	100
	Subnet Mask	255	255	255	0
	Default Gateway	192	168	0	254
	DNS Server	192	168	0	51
	<a href="#">Apply</a>				

[Logout](#)

**Admin > Alert Setup**

Alert Setup	Alert Type	<input type="checkbox"/> Fan Error <input type="checkbox"/> High Temp Warning <input type="checkbox"/> Light Source Error		
	<input checked="" type="checkbox"/> Alert Mail Notification			
	<b>SMTP Setting</b>			
	SMTP Server	<input type="text"/>		
	From	<input type="text"/>		
	Username	<input type="text"/>		
	Password	<input type="text"/>		
	<b>Email Setting</b>			
	Mail Subject	<input type="text"/>		
	Mail Content	<input type="text"/>		
To	<input type="text"/>			
<input type="button" value="Apply"/> <input type="button" value="Send Test Mail"/>				

Logout

**Admin > Crestron**

System Status		
General Setup		
Projector Control		
Network Setup		
Alert Setup		
Crestron		
Reset to Default		
Reboot System		

**Crestron Settings**

Connect to	Control Box	
Control Box IPID	7	
Control Box IP	255.255.255.255	Off-line
Control Box Port	41794	
VC4 RoomID		
RoomView IPID	5	
Device Username		
Device Password		
Use SSL	Disable	
Use Certificate	Disable	
Upload Certificate File	<span>Upload File</span>	
FITC Registration URL		
FITC Registration Port	443	Off-line
Auto Discovery	Enable	<span>Apply</span>

Logout

**Admin > Crestron**

System Status		
General Setup		
Projector Control		
Network Setup		
Alert Setup		
Crestron		
Reset to Default		
Reboot System		

Device Username		
Device Password		
Use SSL	Disable	
Use Certificate	Disable	
Upload Certificate File	<span>Upload File</span>	
FITC Registration URL		
FITC Registration Port	443	Off-line
Auto Discovery	Enable	<span>Apply</span>

**XrO Information**

MAC Address	00.60.e9.00.00.01	Off-line
Serial Number		

**System Time Settings**

Current Time	2021-11-01 00:03:52	
NTP Function	<input checked="" type="radio"/> Enable <input type="radio"/> Disable	
NTP Server	time.nist.gov	
Time Zone	+8	<span>Apply</span>

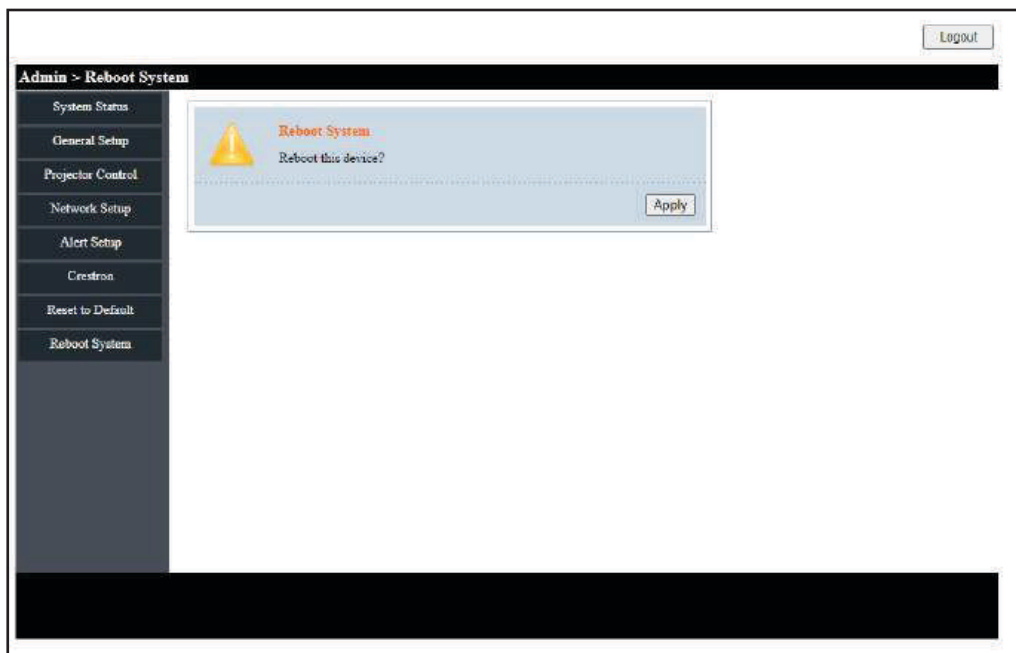
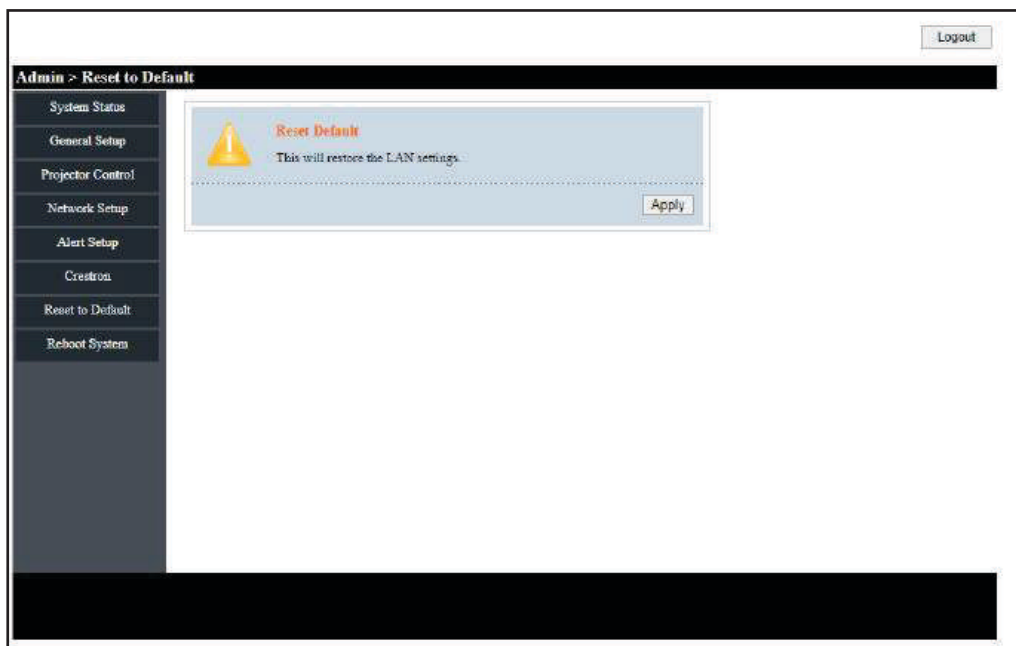

### INFORMATION

Only applicable to Superior Series.

## 8.14 DIRECTLY CONNECTING A COMPUTER TO THE PROJECTOR

1. Select **Network > LAN > DHCP**.
2. Select **Off**.
3. Press **Enter**.
4. Select **Network > LAN**.
5. Configure the IP address, Subnet Mask, Gateway, and DNS settings.
6. Set the computer to use the same IP address, subnet mask, gateway, and DNS settings.
7. Open a web browser.
8. Type the projector's IP address type the user name and password. The default user name and password is **admin**.



### INFORMATION

Only applicable to Superior Series.

## 9. CLEANING

Do not use canned air or any type of abrasive pad, paper towel, scouring powder, glass cleaner, or solvent (such as alcohol, paint thinner or benzene).

Unplug the projector before cleaning.

### 9.1 CLEANING THE LENS

Clean the projector's lens with a lightly damp cloth. Do not spray liquid directly onto the lens.

### 9.2 CLEANING THE CASE

Clean the projector's case using a lightly damp cloth.

### 9.3 CLEANING THE AIR VENTS

Clean the air intake vents with a soft and dry cloth, a soft brush, or a small vacuum cleaner designed for cleaning electrical devices.

## 10. SANITATION

- Using only lightly dampened microfibre cloth to avoid malfunction and possible permanent damage to electronic parts, lightly clean the surface of the product, avoiding any connection points, ventilation holes or the lens.
- After the application, dry the product with a clean and dry microfibre cloth.

Please follow all safety and handling instructions listed with the cleaning solution and keep out of reach of children. For schools conducting an overall deep clean of their facilities, here are steps to appropriately protect your InFocus product in advance of chemicals being sprayed or fogging devices being employed:

- Disconnect the product from its power source.
- Cover the product to prevent damage to internal electronic components.
- Remember to remove any covering before use.

Please ensure that those with access to your InFocus products are aware of the cleaning procedure.



## ATTENTION

Ensure your InFocus product is fully covered on all sides before facilities deep cleaning. Chemicals must not be allowed to enter or be sprayed on to the surface of the product, this will avoid any damage to the internal electronic components and outer casing parts.



## INFORMATION

Good personal hygiene practices of washing and drying hands should be employed before and after use of InFocus products.

Should you have any questions relating to these procedures please contact InFocus Technical Support. Contact details can be found [Here](#).

## 11. DISPOSAL

### 11.1 DISPOSAL OF ELECTRICAL COMPONENTS

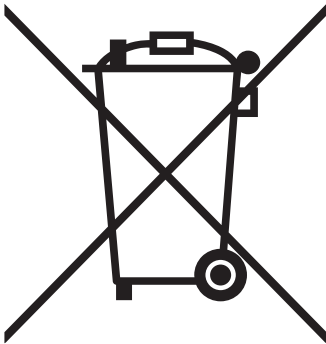

The symbol on the product, the accessories or packaging indicates that this device shall not be treated as unsorted municipal waste, but shall be collected separately. Dispose of the device via a collection point for the recycling of waste electrical and electronic equipment if you live within the EU and in other European countries that operate separate collection systems for waste electrical and electronic equipment. By disposing of the device in the proper manner, you help to avoid possible hazards for the environment and public health that may otherwise be caused by improper treatment of waste equipment. The recycling of materials contributes to the conservation of natural resources.

### 11.2 DISPOSAL OF PACKAGING WASTE

The packaging is made of environmentally friendly materials, which may be disposed of through your local recycling facilities. By disposing of the packaging and packaging waste in the proper manner, you help to avoid possible hazards for the environment and public health.

### 12.1 LED INDICATOR LIGHTS

The following table describes the LED indicator light colours and their meaning.

LED	INDICATOR	MEANING
Power	Blue solid	Normal operation
Power	Blue flashing	The projector is warming up, shutting down, or cooling down. The remote control may be disabled while the indicator is flashing blue.
Power	Red solid	Standby mode
Power	Off	Off or Sleep mode
Lamp	Red flashing	lamp failure
Temperature	Red flashing	Fan failure
Temperature	Red solid	Over temperature

The projector will automatically shutdown if there is a laser failure, a fan failure or if the projector has overheated. Unplug the power cable from the projector, wait 30 seconds, and try again. If the warning indicators light up or flash, contact your nearest service center for assistance.

### 12.2 SOLVING ON / OFF ISSUES

The following table provides solutions for potential issues that may occur when the projector is turned on or off.

ISSUE	CAUSE	SOLUTION
Projector will not turn on.	No power	Check that the power cable is connected. Check that the power indicator is on.
Projector will not turn on.	The projector has overheated	Make sure there is at least 30cm of clearance around the intake and exhaust vents. Wait five minutes and try turning the projector on again. If the projector is being used above 5500 ft/1600 m, use the On Screen Display (OSD) menu to set High Altitude to on.
Projector turns off by itself.	The Auto Power Off timer is set	Use the On Screen Display (OSD) menu to adjust the auto power of setting.

### 12.3 SOLVING IMAGE ISSUES

The following table provides solutions for potential image issues.

ISSUE	CAUSE	SOLUTION
No image	Incorrect source is selected.	Press the SOURCE button or one of the source buttons again.
No image	Source cable is not connected.	Ensure the source cable is securely connected to the projector and source device
No image	Source is not playing	Make sure the source has not stopped or paused the video. If the source is a computer, make sure the PC is not in a screen saving or power saving mode and resend the video to the projector.
No image	AV-Mute is on	Ensure the AV-MUTE (video off) buttons has not been pressed.
No image	Brightness and/or contrast setting is too low	Use the On Screen Display (OSD) menu to adjust the brightness and contrast
Image is reversed	Orientation is set incorrectly.	Use the On Screen Display (OSD) menu to adjust the orientation.
Image has slanted sides	Projector is not positioned perpendicularly to the screen.	Ensure the projector is centered on the screen and below the bottom of the screen
Image has slanted sides	Keystone is not set correctly.	Press the keystone + or - buttons to adjust the image alignment.

ISSUE	CAUSE	SOLUTION
<b>Image is too small or too large.</b>	Projector is too far from or too close to the screen.	Move the projector
<b>Image is too small or too large.</b>	The zoom is not set correctly.	Press the Zoom + or - buttons to adjust the zoom.
<b>Image is too dark</b>	ECO mode is enabled	Check if the projector is in the Forced ECO mode because the ambient temperature is too high.
<b>Image is blurry</b>	Focus is not set correctly.	Use the focus ring to adjust the focus.
<b>Image is blurry</b>	Projector is too close or too far from the screen.	Ensure that the distance between the projector and screen is within the adjustment range of the lens.
<b>Image is blurry</b>	Smudge or condensation on the lens.	Clean the lens. Condensation may form on the lens if the projector is cold, brought into a warm place, and turned on.
<b>Image is scrolling or flickering.</b>	Source resolution and/or frequency is not supported.	Make sure that the source's resolution and frequency are supported by the projector.

## 12.4 SOLVING VIDEO, AUDIO AND REMOTE CONTROL ISSUES

The following table provides solutions for potential video, audio, and remote control issues.

ISSUE	CAUSE	SOLUTION
<b>Video is frozen</b>	The Freeze button has been pressed.	Press the Freeze button on the remote to unfreeze the video.
<b>Video is stretched</b>	16:9 (wide) source is setup incorrectly.	Ensure the source is set to use the 16:9 (wide) display format.
<b>Video is stretched</b>	Letterbox (LBX) source is setup incorrectly.	Use the On Screen Display (OSD) menu to set the aspect ratio to LBX.
<b>Video is stretched</b>	4:3 source is setup incorrectly.	Use the On Screen Display (OSD) menu to set the aspect ratio to 4:3.
<b>No audio</b>	Projector is muted.	Press the Mute button to unmute the projector.
<b>No audio</b>	Volume setting is too low.	Press the volume + button to increase the volume.
<b>No audio</b>	Source cable is not connected.	Ensure the source cable is securely connected to the projector and source device.
<b>No audio</b>	Source is muted.	Ensure the source has not been muted.
<b>Remote does not work.</b>	Batteries expired.	Install new batteries.
<b>Remote does not work.</b>	Batteries installed incorrectly.	Remove and reinstall the batteries.
<b>Remote does not work.</b>	Remote is too far from projector.	The remote should be within 16.4 feet (5m) of the projector.
<b>Remote does not work.</b>	IR receiver cannot detect remote.	Ensure there are no obstructions between the remote and the projector's IR receiver. Ensure the operating angle of the remote control is within $\pm 20^\circ$ to the projector's IR receiver. Ensure there are no fluorescent light sources shining on the projector's IR receiver.

## 12.5 SERVICING

Servicing is required when the projector has been damaged, exposed to rain or moisture, does not operate normally, or has been dropped. All servicing and repairs should be performed by an authorized InFocus representative.



## 13.1 RS232 PIN ASSIGNMENTS

PIN NUMBER	BO DETAILED TIMING
1	-
2	RDX
3	TXD
4	-
5	GND
6	-
7	-
8	-
9	-

## 13.2 RS232 PROTOCOL FUNCTION LIST

FUNCTION	VALUE
BAUD RATE	1920
PARITY BIT	NONE
DATA BIT	8
STOP BIT	1
LASER ON DELAY	20 SECONDS
POWER DOWN DELAY	20 SECONDS
SOURCE CHANGE DELAY	8 SECONDS
INTERCOMMAND DELAY MINIMUM	500 MILLISECONDS
INTERCHARACTER DELAY MINIMUM	2 MILLISECONDS

## 13.3 SUPPORTED RESOLUTIONS AND REFRESH RATES

### Video Compatibility

NTSC	NTSC M/J, 3.58MHz, 4.43MHz
PAL	PAL B/D/G/H/I/M/N, 4.43MHz
SECAM	SECAM B/D/G/K/K1/L, 4.25/4.4 MHz
SDTV	480i/p, 576i/p
HDTV	720p(50/60Hz), 1080i(50/60Hz), 1080P(50/60Hz)

**Note** Video timing detail

SIGNAL	RESOLUTION	REFRESH RATE (Hz)	NOTES
TV (NTSC)	720×480	60	For Composite Video /S-video
TV (PAL,SECAM)	720×576	50	
SDTV (480i)	720×480	60	For Component
SDTV (480P)	720×480	60	
SDTV (576i)	720×576	50	
SDTV (576P)	720×576	50	
HDTV (720p)	1280×720	50/60	
HDTV (1080i)	1920×1080	50/60	
HDTV (1080p)	1920×1080	24/50/60	

True 3D Video Compatibility table

INPUT RESOLUTIONS	HDMI 1.4a 3D Input	Input timing		
		1280×720P @ 50Hz	Top-and-Bottom	
	1280×720P @ 60Hz	Top-and-Bottom		
	1280×720P @ 50Hz	Frame packing		
	1280×720P @ 60Hz	Frame packing		
	1920×1080i @50 Hz	Side-by-Side (Half)		
	1920×1080i @60 Hz	Side-by-Side (Half)		
	1920×1080P @24 Hz	Top-and-Bottom		
	1920×1080P @24 Hz	Frame packing		
	HDMI 1.3	1920×1080i @ 50Hz	SBS mode is on	
		1920×1080i @ 60Hz		
		1280×720P @50Hz		
		1280×720P @60Hz		
		800×600 @ 60Hz		
		1024×768 @ 60Hz		
	HDMI 1.3	1920×1080i @ 50Hz	TAB mode is on	
		1920×1080i @ 60Hz		
		1280×720P @50Hz		
		1280×720P @60Hz		
		800×600 @ 60Hz		
		1024×768 @ 60Hz		
		480i	HQFS	3D format is Frame sequential

If 3D input is 1080p@24Hz, the DMD should replay with integral multiple with 3D mode Support NVIDIA 3DTV Play if there is no patent fee from InFocus

**Note** 1080i@25Hz and 720p@50Hz will run in 100Hz; other 3D timing will run in 120Hz.

VESA standards Computer Signal (Analog RGB Compatible)

SIGNAL	RESOLUTION	REFRESH RATE(HZ)	NOTES FOR MAC
VGA	640×480	60/67/ 72/85	Mac 60/ 72/85/
SVGA	800×600	56/60 (*2)/ 72/85/120 (*2)	Mac 60/ 72/85
XGA	1024×768	48/50/60 (*2)/ 70/ 75/85/120 (*2)	Mac 60/ 70/ 75/85
HDTV(720P)	1280×720	50/60 (*2)/120 (*2)	Mac 60
WXGA	1280×768	60/ 75/85	Mac 60/ 75/85
	1280×800	48/50/60	Mac 60
WXGA (*3)	1366×768	60	
SXGA	1280×1024	60/ 75/85	Mac 60/ 75
SXGA+	1400×1050	60	
UXGA	1600×1200	60	
HDTV(1080p)	1920×1080	24/50/60	Mac 60
WUXGA	1920×1200 (*1)	60/50hz	Mac 60

(\*1) 1920×1200 @60Hz only support RB (reduced blanking)

(\*2) Support 3D timing for 3D Ready projector (STD) and True 3D projector (Option)

(\*3) Window 10 standard timing

### 13.4 ON SCREEN DISPLAY (OSD) MENU TREE

#### IMAGE

SETTING 1	SETTING 2	SETTING 3	VALUES	COMMENTS
Picture Mode			Presentation	1. RGB source default: Presentation 2. YUV source default: Movie 3. 3D on default: 3D 4. ISF Day and ISF Night are valid while ISF Mode is On or Unlock
			Bright	
			Movie	
			sRGB	
			DICOM SIM.	
			User	
			3D	
			ISF Day	
Wall Colour			Whiteboard	
			Blackboard	
			Light Yellow	
			Light Green	
			Light Blue	
			Pink	
			Gray	
Brightness			-50 ~ 50	
Contrast			-50 ~ 50	
Sharpness			1 ~ 15	
Colour			-50 ~ 50	Only for YUV source
Tint			-50 ~50	Only for YUV source

SETTING 1	SETTING 2	SETTING 3	VALUES	COMMENTS
Advanced	Gamma		Film	<ol style="list-style-type: none"> <li>Picture Mode is DICOM SIM. Gamma item will be hide.</li> <li>Wall Colour is Blackboard. Gamma item will be hide.</li> </ol>
			Video	
			Graphics	
			Standard (2.2)	
			1,8	
			2,0	
			2,4	
	BrilliantColorTM		1 ~ 10	
	Colour Temp		Warm	
			Medium	
			Cold	
	Colour Settings	Red- Hue	-50 ~ 50	
		Red- Saturation	-50 ~ 50	
		Red- Gain	-50 ~ 50	
		Exit		
	Colour Settings	Green- Hue	-50 ~ 50	
		Green- Saturation	-50 ~ 50	
		Green- Gain	-50 ~ 50	
		Exit		
		Blue- Hue	-50 ~ 50	
		Blue- Saturation	-50 ~ 50	
		Blue- Gain	-50 ~ 50	
		Exit		
		Cyan- Hue	-50 ~ 50	
		Cyan- Saturation	-50 ~ 50	
		Cyan- Gain	-50 ~ 50	
		Exit		
		Magenta- Hue	-50 ~ 50	
		Magenta- Saturation	-50 ~ 50	
		Magenta- Gain	-50 ~ 50	
		Exit		
		Yellow- Hue	-50 ~ 50	
		Yellow- Saturation	-50 ~ 50	
		Yellow- Gain	-50 ~ 50	
		Exit		
		White- Red	-50 ~ 50	
		White- Green	-50 ~ 50	
		White- Blue	-50 ~ 50	
		Exit		
	Reset			
Exit				

SETTING 1	SETTING 2	SETTING 3	VALUES	COMMENTS	
Advanced	RGB Gain/Bias	Red Gain	-50 ~ 50		
		Green Gain	-50 ~ 50		
		Blue Gain	-50 ~ 50		
		Red Bias	-50 ~ 50		
		Green Bias	-50 ~ 50		
		Blue Bias	-50 ~ 50		
		Reset			
		Exit			
	Colour Space			AUTO	
				RGB	Only for non-HDMI source
				RGB (0~255)	Only for HDMI source
				RGB (16~235)	Only for HDMI source
				YUV	
	White Level			0 ~ 31	Only for Video
	Black Level			-5 ~ 5	Only for Video
	IRE			0	For Video Input Source NTSC Signal default: 7.5 PAL - Signal default: 0 IRE Adjustment Only for NTSC-M/ NTSC-J/NTSC-4.43/PAL-M/ PAL-60
				7,5	
	Signal	Automatic		Off	Only for Analog VGA source
				On	
		Phase		0 ~ 31	
		Frequency		-10 ~ 10	
		H. Position		-5 ~ 5	
		V. Position		-5 ~ 5	
Exit					
Exit					

Display



**INFORMATION**

Zoom has a total of 30 step adjustment, each step representing 0.04× adjustment from -0.8 to 2.0×  
Brightness Power, each step represents 5% power adjustment from 100% to 50%.

SETTING 1	SETTING 2	SETTING 3	VALUES	COMMENTS
Format			4:3	
			16:9	For all models but WXGA models depend on Screen Type selection
			16:10	Only for WXGA models depend on Screen Type selection
			LBX	Only for WXGA, 1080p models.
			Native	Original image without any scaling
			Auto	
Edge Mask			0 ~ 10	
Zoom			-5 ~ 25	

SETTING 1	SETTING 2	SETTING 3	VALUES	COMMENTS
Image Shift	H		-100 ~ 100	One step: 2
	V		-100 ~ 100	One step: 2
	Exit			
V Keystone			-40 ~ 40	for RT
			-20 ~ 20 (TBD)	for ST <b>Note:</b> the V keystone range of 1080p ST: -10~10 in 3D mode by DDP4422 limitation
3D	3D Mode		Off	
			DLP-Link	
	3D-2D		3D	
			L	Only display left frame
		R	Only display right frame	
	3D Format		Auto	
			SBS	SBS = Side by Side Half
			Top and Bottom	
	3D Sync. Invert		Off	
			On	
Exit				
Enhanced Gaming			Off	<ol style="list-style-type: none"> <li>1. Only for 1920x1080 60Hz timing</li> <li>2. Disable Keystone/Overscan/Zoom/Image Shift/Aspect Ratio when turn On</li> </ol>
			On	
Picture Mode Lock			Off	
			On	

### Audio

SETTING 1	SETTING 2	SETTING 3	VALUES
Mute	-	-	Off / On (ICON)
Volume	-	-	0-10

Setup



**INFORMATION**

**Power Mode, Eco/Active – Eco disables LAN and puts USB in to standby mode, Active leaves LAN active and USB in to standby.**

SETTING 1	SETTING 2	SETTING 3	VALUES	REMARK
Language			English	English
			Deutsch	German
			Français	French
			Svenska	Swedish
			Español	Spanish
			Português	Portuguese
			Polski	Polish
			Nederlands	Dutch
			हिंदी	Hindi
			Norsk/Dansk	Norwegian/Danish
			Pilipino	Filipino
			Melayu	Malay
			Română	Romanian
			Italiana	Italian
			简体中文	Simplified Chinese
			Suomi	Finnish
			ελληνικά	Greek
			Русский	Russian
			Magyar	Hungarian
			Čeština	Czech
			العربية	Arabic
ไทย	Thai			
Türkçe	Turkish			
فارسی	Farsi			
Tiếng Việt	Vietnamese			
Bahasa Indonesia	Indonesian			
বাংলা	Bengali			
Projection			Front (ICON)	
			Rear (ICON)	
			Front-Ceiling (ICON)	
			Rear-Ceiling (ICON)	
Menu Location			Top-Left (ICON)	
			Top-Right (ICON)	
			Center (ICON)	
			Bottom-Left (ICON)	
			Bottom-Right (ICON)	
Screen Type			16:10	1. Only for WXGA models 2. Relate to Format
			16:9	

SETTING 1	SETTING 2	SETTING 3	VALUES	REMARK
Security	Security		Off	Default PIN: 1234
			On	
	Security Timer	Month	0 ~ 12	
		Day	0 ~ 30	
		Hour	0 ~ 24	
Change Password			PIN is 4 digitals	
Project ID			0 ~ 99	
Audio Settings	Mute		Off	
			On	
	Volume		0 ~ 10	
	Audio Input		Default	Only for HDMI source
			AUDIO IN	
Exit				
HDMI Link Settings	HDMI Link		Off	
			On	
	Power On Link		Mutual	
			PJ -> Device	
			Device -> PJ	
	Power Off Link		Off	
		On		
Network	Network State		Connect/Disconnect	DHCP Off, default IP configure setting: IP Address: 192.168.0.100 Subnet Mask: 255.255.255.0 Gateway: 192.168.0.254 DNS: 192.168.0.1 Support Network Functions: Crestron 2.0 => Port 41794 Extron => Port 2023 AMX Device Discovery => Port 9131 PJ Link => Port 4352 Telnet => Port 23 HTTP => Port 80, Webpage Control
	DHCP		Off	
			On	
	IP Address		xxx.xxx.xxx.xxx	
	Subnet mask		xxx.xxx.xxx.xxx	
	Gateway		xxx.xxx.xxx.xxx	
	DNS		xxx.xxx.xxx.xxx	
	Apply	Yes		
No				
Exit				
Advanced	Logo		Default	
			Neutral	Same as below Background Colour setting
	Background Colour		Black	
			Red	
			Blue	
			Green	
			White	
			Logo	
	Information Hide		Off	Warning message & power off not hide
			On	
	Exit			



**OPTIONS**

SETTING 1	SETTING 2	SETTING 3	VALUES	COMMENTS	
Input Source			VGA		
			Video		
			HDMI 1		
			HDMI 2		
			Exit		
Auto Source			Off		
			On		
High Altitude			Off		
			On		
Keypad Lock			Off	<ol style="list-style-type: none"> <li>Keypad unlock hotkey: Press the "Enter" key on keypad for 5s to release keypad lock</li> <li>Relate to IR Function: If Keypad Lock setting from Off to On, IR Function will be automatically changed to On.</li> </ol>	
			On		
Test Pattern			Red Grid		
			Green Grid		
			Blue Grid		
			White		
Remote Settings	IR Function		Off	Relate to Keypad Lock: If IR Function setting from On to Off, Keypad Lock will be automatically changed to Off.	
			On		
	User 1			AV Mute	Executed through the AV "Mute" key on the remote control
				Wall Colour	
				Brightness	
				Contrast	
				Gamma	
				Colour Temp.	
				Colour Settings	
				RGB Gain/Bias	
				Language	
				Projection	
				Security	
				Test Pattern	
				Auto Power Off (min)	
				Sleep Timer (min)	
				Lamp Settings	
				INFO	
				Advanced	
On					
Signal Power On			Off		
			On		
Auto Power Off (min)			0 ~ 180		One step: 5
Sleep Timer (min)			0 ~ 990		One step: 30

SETTING 1	SETTING 2	SETTING 3	VALUES	COMMENTS
Advanced	Quick Resume		Off	
			On	
	VGA Out (Standby)		Off	
			On	
	USB Power		Off	Standby not supported
On				
Exit				
Lamp Settings	Lamp Hours		(DisplayOnly)	Range 0-99999
	Lamp Reminder		Off	
			On	
	Brightness Mode		Bright	
			Eco	
			Dynamic	
	Lamp Reset		No	
Yes				
Exit				
Reset			No	
			Yes	

## Information



### INFORMATION

The information menu provides information on the active source and other details of the projector, there are no adjustable settings in this section of the menu.

SETTING 1	SETTING 2	SETTING 3	VALUES	COMMENTS
Regulatory			P122 for RT P123 for ST	
Serial Number			(DisplayOnly)	
Input Source			(DisplayOnly)	
Resolution			(DisplayOnly)	
Refresh Rate			(DisplayOnly)	
Picture Mode			(DisplayOnly)	
Lamp Hours	Bright		(DisplayOnly)	Range 0~99999
	Eco.		(DisplayOnly)	Range 0~99999
	Dynamic		(DisplayOnly)	Range 0~99999
	Total		(DisplayOnly)	Range 0~99999
Brightness Mode			(DisplayOnly)	
Firmware Version	System		(DisplayOnly)	
	MCU		(DisplayOnly)	
Project ID			(DisplayOnly)	

# 14. SPECIFICATIONS



## INFORMATION

All specifications are subject to change without notice.

### 14.1 VISTA II, P122 & P123, SPECIFICATIONS

	IN0044SL	IN0046SL	IN0048SL	IN0044ST	IN0046ST	IN0048ST
<b>IMAGE</b>						
Product Series	VISTA II					
Display Technology	Texas Instruments DLP®					
Panel Size	0.55" DMD	0.65" DMD	0.65" DMD	0.55" DMD	0.65" DMD	0.65" DMD
Native Resolution	XGA	WXGA	1080p	XGA	WXGA	1080p
Pixels	1024×768	1280×800	1920×1080	1024×768	1280×800	1920×1080
Aspect Ratio	4:3	16:10	16:9	4:3	16:10	16:9
Contrast Ratio	30000:1					
Brightness (Lumens)	4600	4700	4400	4200	4300	4000
Light Source	UHP Lamp					
Light Source Life Maximum Hours	15000					
Maximum Supported Resolution	1920×1200					
Horizontal Sync. Range (KHz)	15 ~ 97.55					
Vertical Sync. Range (Hz)	54 ~ 85					
Uniformity (%)	80					
<b>LENS</b>						
Lens	1.3×			1:1 Fixed		
Lens Zoom Adjustment	Manual			-		
Image Offset (%)	115	112,4	116	115	112,4	116
Focal Length (mm)	21.85 ~ 24.01			7,15		
F-Stop	2,43	2,7	2,43	2,8	2,43	2,8
Keystone Adjustment	Manual/Automatic					
Vertical Keystone Correction	± 40°			± 20°		
Projection Factor	1.48~1.93:1	1.19~1.54:1	1.13~1.47:1	0,617:1	0,521:1	0,496:1
Projection Distance (Meters/Feet)	1.0 ~ 9.1 / 3.28 ~ 29.85	1.0 ~ 7.7 / 3.28 ~ 22.26	1.0 ~ 10.0 / 3.28 ~ 32.80	0.4 ~ 3.8 / 1.31 ~ 12.46	0.4 ~ 3.4 / 1.31 ~ 11.15	0.4 ~ 3.3 / 1.31 ~ 10.82
Optical Zoom	1.3:1			1:1		
Digital Zoom Demagnification / Magnification	0.8× ~ 2.0×					
Focus Adjustment	Manual					
<b>CONNECTIVITY—INPUTS</b>						
Mini D-sub 15-pin (VGA)	☑					
Composite Video	☑					
S-Video	-					
HDMI™ 1.4	☑☑					
RJ45 - LAN 10/100/1000	☑					
3.5 mm Stereo Mini Jack	☑					

	IN0044SL	IN0046SL	IN0048SL	IN0044ST	IN0046ST	IN0048ST
<b>CONNECTIVITY – OUTPUTS</b>						
Mini D-sub 15-pin (VGA)			☑			
3.5 mm Stereo Mini Jack			☑			
Powered USB-A for Wireless Dongle			☑			
<b>CONNECTIVITY - OTHER</b>						
RS232			☑			
All Major 3D Formats			☑			
USB-A for Service			☑			
<b>POWER</b>						
Power Supply	100 ~ 240 V AC; 50 ~ 60 Hz					
Power Consumption Max (W)	267					
Power Consumption Min. (W)	210					
Power Consumption Network Standby (W)	<2.0					
Power Consumption Standby (W)	<0.5					
<b>GENERAL</b>						
Product Dimensions (L x W x H) (mm / in)	313 x 236 x 96.4 / 12.4 x 9.3 x 3.8					
Product Weight (Kilograms/Pounds)	2.9 / 6.4					
Packaged Dimensions (L x W x H) (mm / in)	395 x 337 x 166 / 15.6 x 13.3 x 6.5					
Packaged Weight (Kilograms/Pounds)	4.1 / 9.0					
Fan Noise (dB)	27					
Audio (W)	1 x 10					
Operating Temperature (Celsius/ Fahrenheit)	5 ~ 40 / 41 ~ 104					
Operating Humidity (%)	10 ~ 85					
Max Operating Altitude (meters / feet)	3048 / 10000					
Storage Temperature (Celsius/ Fahrenheit)	-10 ~ 60 / 14 ~ 140					
Storage Humidity (%)	10 ~ 85					
Security	Kensington Security Slot™, PIN Code Lock & Timer					
Safety and Regulatory	CB, CE, EAC, cTUVus, CCC, FCC, UKCA, NOM, PSB, BIS					
Environmental	WEEE, EU RoHS, China RoHS, CEL, CECP					
<b>IN THE BOX</b>						
Projector	☑	☑	☑	☑	☑	☑
Simplified Users Guide	☑	☑	☑	☑	☑	☑
VGA Cable	☑	☑	☑	☑	☑	☑
Regional Power Cord	☑	☑	☑	☑	☑	☑
Remote Control (no Battery)	☑	☑	☑	☑	☑	☑

## 14.2 GENESIS III, P124, SPECIFICATIONS

	IN0002SL	IN0004SL	IN0006SL
<b>IMAGE</b>			
Product Series	GENESIS III		
Display Technology	Texas Instruments DLP®		
Panel Size	0.55" DMD		0.65" DMD
Native Resolution	SVGA	XGA	WXGA
Pixels	800×600	1024×768	1280×800
Aspect Ratio	4:3		16:10
Contrast Ratio	30000:1		
Brightness (Lumens)	4000		
Light Source	UHP Lamp		
Light Source Life Maximum Hours	15000		
Maximum Supported Resolution	1920×1200		
Horizontal Sync. Range (KHz)	15 ~ 97.55		
Vertical Sync. Range (Hz)	54 ~ 85		
Uniformity (%)	80		
<b>LENS</b>			
Lens	1.1×		
Lens Zoom Adjustment	Manual		
Image Offset (%)	115	112,4	
Focal Length (mm)	21.85 ~ 24.01		
F-Stop	2,41		
Keystone Adjustment	Manual/Automatic		
Vertical Keystone Correction	± 40°		
Projection Factor	1.94 ~ 2.16:1		1.54 ~ 1.72:1
Projection Distance (Meters/Feet)	1.2 ~ 12.0 / 3.94 ~ 39.36		1.0 ~ 10.0 / 3.28 ~ 32.80
Optical Zoom	1.1:1		
Digital Zoom Demagnification / Magnification	0.8× ~ 2.0×		
Focus Adjustment	Manual		
<b>CONNECTIVITY—INPUTS</b>			
Mini D-sub 15-pin (VGA)	☑		
Composite Video	—		
S-Video	☑		
HDMI™ 1.4	☑		
RJ45 - LAN 10/100/1000	—		
3.5 mm Stereo Mini Jack	☑		
<b>CONNECTIVITY—OUTPUTS</b>			
Mini D-sub 15-pin (VGA)	—		
3.5 mm Stereo Mini Jack	☑		
Powered USB-A for Wireless Dongle	☑		

	IN0002SL	IN0004SL	IN0006SL
<b>CONNECTIVITY - OTHER</b>			
RS232		–	
All Major 3D Formats		☑	
USB-A for Service		☑	
<b>POWER</b>			
Power Supply	100 ~ 240 V AC; 50 ~ 60 Hz		
Power Consumption Max (W)	267		
Power Consumption Min. (W)	210		
Power Consumption Network Standby (W)	<2.0		
Power Consumption Standby (W)	<0.5		
<b>GENERAL</b>			
Product Dimensions (L x W x H) (mm / in)	313 x 236 x 96.4 / 12.4 x 9.3 x 3.8		
Product Weight (Kilograms/Pounds)	2.9 / 6.4		
Packaged Dimensions (L x W x H) (mm / in)	395 x 337 x 166 / 15.6 x 13.3 x 6.5		
Packaged Weight (Kilograms/Pounds)	4.1 / 9.0		
Fan Noise (dB)	27		
Audio (W)	1 x 10		
Operating Temperature (Celsius/ Fahrenheit)	5 ~ 40 / 41 ~ 104		
Operating Humidity (%)	10 ~ 85		
Max Operating Altitude (meters / feet)	3048 / 10000		
Storage Temperature (Celsius/ Fahrenheit)	-10 ~ 60 / 14 ~ 140		
Storage Humidity (%)	10 ~ 85		
Security	Kensington Security Slot™, PIN Code Lock & Timer		
Safety and Regulatory	CB, CE, EAC, cTUVus, CCC, FCC, UKCA, NOM, PSB, BIS		
Environmental	WEEE, EU RoHS, China RoHS, CEL, CECP		
<b>IN THE BOX</b>			
Projector	☑	☑	☑
Simplified Users Guide	☑	☑	☑
VGA Cable	☑	☑	☑
Regional Power Cord	☑	☑	☑
Remote Control (no Battery)	☑	☑	☑

### 14.3 GENESIS IV P125 & P126, SPECIFICATIONS

	IN0022SL	IN0024SL	IN0026SL	IN0028SL	IN0024ST	IN0026ST
<b>IMAGE</b>						
Product Series	GENESIS IV					
Display Technology	Texas Instruments DLP®					
Panel Size	0.55" DMD		0.65" DMD	0.47" DMD	0.55" DMD	0.65" DMD
Native Resolution	SVGA	XGA	WXGA	1080p	XGA	WXGA
Pixels	800×600	1024×768	1280×800	1920×1080	1024×768	1280×800
Aspect Ratio	4:3		16:10	16:9	4:3	16:10
Contrast Ratio	30000:1					
Brightness (Lumens)	4000				3800	
Light Source	UHP Lamp					
Light Source Life Maximum Hours	15000					
Maximum Supported Resolution	1920×1200					
Horizontal Sync. Range (KHz)	15 ~ 97.55					
Vertical Sync. Range (Hz)	54 ~ 85					
Uniformity (%)	80					
<b>LENS</b>						
Lens	1.1×				1:1 Fixed	
Lens Zoom Adjustment	Manual				-	
Image Offset (%)	115	112,4	116	115	112,4	
Focal Length (mm)	21.85 ~ 24.01				7,15	
F-Stop	2,41			2,1	2,7	2,8
Keystone Adjustment	Manual/Automatic					
Vertical Keystone Correction	± 40°				± 20°	
Projection Factor	1.94 ~ 2.16:1		1.54 ~ 1.72:1	1.47 ~ 1.62:1	0.621:1	0.52:1
Projection Distance (Meters/Feet)	1.2 ~ 12.0 / 3.94 ~ 39.36		1.0 ~ 10.0 / 3.28 ~ 32.80	1.0 ~ 9.8m / 3.28 ~ 32.14	0.4 ~ 3.76 / 1.31 ~ 12.33	0.4 ~ 3.37 / 1.31 ~ 11.05
Optical Zoom	1.1:1			1:1		
Digital Zoom Demagnification / Magnification	0.8× ~ 2.0×					
Focus Adjustment	Manual					
<b>CONNECTIVITY—INPUTS</b>						
Mini D-sub 15-pin (VGA)	☑					
Composite Video	-					
S-Video	☑					
HDMI™ 1.4	☑☑					
RJ45 - LAN 10/100/1000	-					
3.5 mm Stereo Mini Jack	☑					
<b>CONNECTIVITY—OUTPUTS</b>						
Mini D-sub 15-pin (VGA)	☑					
3.5 mm Stereo Mini Jack	☑					
Powered USB-A for Wireless Dongle	☑					

	IN0022SL	IN0024SL	IN0026SL	IN0028SL	IN0024ST	IN0026ST
<b>CONNECTIVITY - OTHER</b>						
RS232				☑		
All Major 3D Formats				☑		
USB-A for Service				☑		
<b>POWER</b>						
Power Supply	100 ~ 240 V AC; 50 ~ 60 Hz					
Power Consumption Max (W)	267					
Power Consumption Min. (W)	210					
Power Consumption Network Standby (W)	<2.0					
Power Consumption Standby (W)	<0.5					
<b>GENERAL</b>						
Product Dimensions (L x W x H) (mm / in)	313 x 236 x 96.4 / 12.4 x 9.3 x 3.8					
Product Weight (Kilograms/Pounds)	2.9 / 6.4					
Packaged Dimensions (L x W x H) (mm / in)	395 x 337 x 166 / 15.6 x 13.3 x 6.5					
Packaged Weight (Kilograms/Pounds)	4.1 / 9.0					
Fan Noise (dB)	27					
Audio (W)	1 x 10					
Operating Temperature (Celsius/ Fahrenheit)	5 ~ 40 / 41 ~ 104					
Operating Humidity (%)	10 ~ 85					
Max Operating Altitude (meters / feet)	3048 / 10000					
Storage Temperature (Celsius/ Fahrenheit)	-10 ~ 60 / 14 ~ 140					
Storage Humidity (%)	10 ~ 85					
Security	Kensington Security Slot™, PIN Code Lock & Timer					
Safety and Regulatory	CB, CE, EAC, cTUVus, CCC, FCC, UKCA, NOM, PSB, BIS					
Environmental	WEEE, EU RoHS, China RoHS, CEL, CECP					
<b>IN THE BOX</b>						
Projector	☑	☑	☑	☑	☑	☑
Simplified Users Guide	☑	☑	☑	☑	☑	☑
VGA Cable	☑	☑	☑	☑	☑	☑
Regional Power Cord	☑	☑	☑	☑	☑	☑
Remote Control (no Battery)	☑	☑	☑	☑	☑	☑



### 15.1 FOR USERS IN THE UNITED STATES



#### INFORMATION

##### FCC COMPLIANCE STATEMENT – CLASS B

This equipment generates, uses and can radiate radio frequency energy, and if not installed and used in accordance with the instruction manual may cause interference to radio communications. It has been tested and found to comply with the limits for a Class “B” computing device pursuant to Subpart B of Part 15 of the FCC Rules, which are designed to provide reasonable protection against such interference when operated in a residential installation. However, there is no guarantee that interference will not occur in a particular installation. If this product does cause harmful interference to radio or television reception, or any other form of communication, the user is encouraged to try to correct the interference by one or more of the following measures:

- Reorient or relocate the receiving antenna.
- Increase the separation between the product and receiver.
- Connect the product to an outlet on a circuit different from that to which the receiver is connected.
- Consult the dealer or an experienced radio/TV technician for help.

Any changes or modifications not expressly approved by the party responsible for compliance may void the user’s authority to operate the product. Where shielded interface cables have been provided with the product, specified additional components or accessories elsewhere defined to be used with the installation of the product, they shall be used in order to ensure compliance with FCC regulations.

##### US Importer and Local Representative in accordance with FCC regulations

Maxnerva Technology Services USA LLC  
13190 SW 68th Parkway, Suite 120  
Portland, Oregon 97223.

### 15.2 FOR USERS IN CANADA



#### INFORMATION

This Class B digital apparatus complies with Canadian ICES-003.  
Cet appareil numérique de la classe B est conforme la norme NMB-003 du Canada.

##### INDUSTRY CANADA REGULATORY INFORMATION

Operation is subject to the following two conditions:

- (\*1) this device may not cause interference, and
- (\*2) this device must accept any interference, including interference that may cause undesired operation of the device.

The user is cautioned that this device should be used only as specified within this manual to meet RF exposure requirements. Use of this device in a manner inconsistent with this manual could lead to excessive RF exposure conditions.

**INSTRUCTIONS TO USERS:** This equipment complies with the requirements of FCC equipment provided that the following conditions are met. If the cables include a EMI ferrite core, attach the ferrite core end of the cable to the projector. Use the cables which are included with the projector or specified.

\*\* Changes or modifications not expressly approved by the party responsible for compliance could void the user’s authority to operate the equipment.

Complies with IDA Standards DA103121

## 15.3 FOR USERS IN EUROPEAN UNION



### INFORMATION EU COMPLIANCE



### INFORMATION CE COMPLIANCE STATEMENT

Electromagnetic Compatibility Statement: Meets 2014/30/EU Directive  
Low Voltage Directive: Meets 2014/35/EU Directive

#### EU Importer

Grand Field Technology Limited  
Room 1001, 10/F, Houston Centre, 63 Mody Road, Tsim Sha Tsui East, Kowloon, Hong Kong.

#### EU Authorised Representative

24hour Solutions B.V.  
Van Nelleweg 1,  
3044 BC, Rotterdam,  
The Netherlands  
info@24hour-ar.com  
www.24hour-ar.com

## 15.4 FOR USERS IN THE UNITED KINGDOM AND NORTHERN IRELAND



### INFORMATION UK COMPLIANCE



### INFORMATION UKCA COMPLIANCE STATEMENT

Electromagnetic Compatibility Regulations 2016  
Electrical Equipment (Safety) Regulations 2016  
The Restriction of the Use of Certain Hazardous Substances in Electrical and Electronic Equipment Regulations 2012  
Manufacturer, Importer and Authorised Representative in accordance with national directives

#### Manufacturer

Maxnerva Technology Services Limited  
Room 1001, 10/F, Houston Centre, 63 Mody Road, Tsim Sha Tsui East, Kowloon, Hong Kong.

#### UK Authorised Representative in accordance with UK regulations

24hour Solutions Ltd.  
15 Beaufort Court  
Admirals Way, Canary Wharf  
London, E14 9XL, UK  
+44 (0)20 457 129 06  
Company ID 13630765

## 15.5 FOR USERS IN RUISSIA



### INFORMATION

#### **Russian Authorised Representative**

Maxnerva has appointed AUVIX LLC, 129085, с. Moscow, Zvezdny Boulevard, 21, bldg. 1. as the authorised representative in Russia and this product is compliant with TR TC 004/2011, TR TC 020/2011 and TR CU 020/2011 local conformity testing and approvals.

Махнерва назначил ООО « АУВИКС », 129085, г. Москва, Звездный бульвар, д. 21, стр. 1., в качестве официального представителя в России, и этот продукт соответствует требованиям TR TC 004/2011, TR TC 020/2011 и TR CU 020 /2011г. местные испытания на соответствие и согласования

ООО « АУВИКС »

129085, г. Москва, Звездный бульвар, д. 21, стр. 1

+7 (495) 797-57-75

info@auvix.ru